



Project: \_\_\_\_\_

Customer: \_\_\_\_\_

Engineer: \_\_\_\_\_

Pump Manufacturer: \_\_\_\_\_

## Drawing Submittal Package

### Model GPL Limited Service Full Voltage Across the Line Start Electric Pump Controller



#### Contents:

- Submittal Data Sheets
- Dimensional Data
- Wiring Schematics
- Field Connections

**NOTE: The drawings included in this package are for controllers covered under our standard offering. Actual AS BUILT drawings may differ from what is shown in this package**



# Submittal Data Sheet

## Model GPL Electric Pump Controller

From normal incoming power through Circuit Breaker (CB)\*

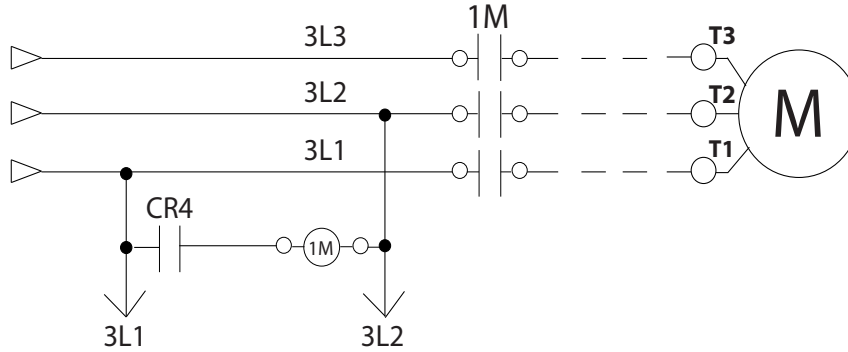

- Starting Method:** Full Voltage  
Across the line (Direct on line)
- Typical Voltage Applied at Start:** 100%
- Inrush Current:** 6 x normal load current
- Starting Torque:** 100%
- Motor Type:** Across the line (Direct on line)
- No. of Contactors:** 1 at 100% of horsepower
- No. of Motor Connections & Sizing:** 3 at 100% of Full load Current (FLC)

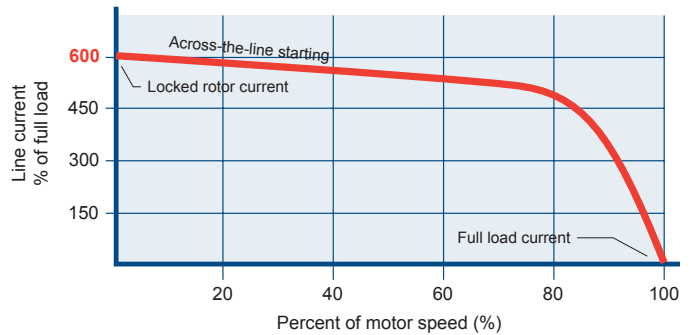

Shortcircuit Withstand Rating	208V to 240V - 3ph - 50/60Hz	380V to 480V - 3ph - 60Hz	600V - 3ph - 60Hz
<input type="checkbox"/> Standard	65,000 A	25,000 A	18,000 A
<input type="checkbox"/> Optional	n/a	65,000 A	25,000 A

<b>Listings, Approvals and Certifications</b>	<b>Standard</b>	
	Underwriters Laboratory (UL)	<ul style="list-style-type: none"> <li>• UL218 - Fire pump controllers</li> <li>• CSA C22.2 No. 14 Industrial Control Equipment</li> </ul>
	New York City	Accepted for use in the City of New York by the Department of Buildings
<b>Enclosure</b>	<b>Protection Rating</b>	
	<input type="checkbox"/> <b>Standard:</b> NEMA 2 <b>Optional</b> <input type="checkbox"/> NEMA 12 <input type="checkbox"/> NEMA 4X-304 sst painted <input type="checkbox"/> NEMA 3 <input type="checkbox"/> NEMA 4X-304 sst brushed finish <input type="checkbox"/> NEMA 3R <input type="checkbox"/> NEMA 4X-316 sst painted <input type="checkbox"/> NEMA 4 <input type="checkbox"/> NEMA 4X-316 sst brushed finish	
	<b>Accessories</b> <ul style="list-style-type: none"> <li>• Wall mounting lugs</li> <li>• Keylock handle</li> </ul>	<b>Paint Specifications</b> <ul style="list-style-type: none"> <li>• Red RAL3002</li> <li>• Powder coating</li> <li>• Glossy textured finish</li> </ul>

\*Please see Disconnecting Means and Locked Rotor Protector details on page 2.



## Submittal Data Sheet Model GPL Electric Pump Controller

<b>Limitations</b>	<ul style="list-style-type: none"> <li>• Across the line starting only</li> <li>• Horsepower rating of maximum 30hp</li> <li>• Can only be installed where acceptable by the authority having jurisdiction</li> <li>• Not accepted in FM insured property</li> </ul>
<b>Pressure Sensing</b>	<ul style="list-style-type: none"> <li>• Pressure transducer for fresh water application</li> <li>• Pressure sensing connection 1/2" Female NPT</li> <li>• Rated for 0-500psi working pressure</li> <li>• Internally mounted</li> </ul>
<b>Surge Suppression</b>	Surge arrestor rated to suppress surges above line voltage
<b>Disconnecting Means &amp; Locked Rotor Protector</b>	Circuit breaker (inverse time non adjustable) rated between 150% and 250% of motor full load current
<b>Service Entrance Rating</b>	Suitable as service entrance equipment
<b>Emergency Start Handle</b>	<ul style="list-style-type: none"> <li>• Push and slide to lock</li> <li>• Across the line start (direct on line)</li> </ul>
<b>Electrical Readings</b>	<ul style="list-style-type: none"> <li>• Voltage phase to phase</li> <li>• Amperage of each phase when motor is running</li> </ul>
<b>Pressure Readings</b>	<ul style="list-style-type: none"> <li>• Continuous system pressure display</li> <li>• Cut-in and Cut-out pressure settings</li> </ul>
<b>Pressure and Event Recorder</b>	<ul style="list-style-type: none"> <li>• Pressure readings with date stamp</li> <li>• Event recording with date stamp</li> <li>• Stored in memory for lifetime of controller</li> <li>• Data viewable on operator interface display screen</li> <li>• Downloadable by USB port to external memory device</li> </ul>



# Submittal Data Sheet

## Model GPL Electric Pump Controller

<b>Audible Alarm</b>	4" alarm bell - 85 dB at 10ft. (3m)		
<b>Visual Indications and Alarms</b>	<ul style="list-style-type: none"> <li>• Power available</li> <li>• Phase reversal</li> <li>• Motor run</li> <li>• Pump room alarm</li> <li>• Motor trouble</li> <li>• Phase loss</li> <li>• Phase unbalance</li> <li>• Low water level</li> </ul>	<ul style="list-style-type: none"> <li>• Locked rotor</li> <li>• Periodic test</li> <li>• Fail to start</li> <li>• Low discharge pressure</li> <li>• Low pump room temperature</li> <li>• Pump room temperature (°F or °C)</li> <li>• Pump on demand/Automatic start</li> <li>• Emergency start</li> </ul>	<ul style="list-style-type: none"> <li>• Manual start</li> <li>• Deluge valve start</li> <li>• Remote automatic start</li> <li>• Remote manual start</li> <li>• Overcurrent</li> <li>• Undercurrent</li> <li>• Undervoltage</li> <li>• Overvoltage</li> </ul>
<b>Remote Alarm Contacts</b>	SPDT-8A-250V.AC <ul style="list-style-type: none"> <li>• Power available</li> <li>• Phase reversal</li> <li>• Motor run</li> <li>• Common pump room alarm               <ul style="list-style-type: none"> <li>• Overvoltage</li> <li>• Low pump room temperature</li> </ul> </li> <li>• Common motor trouble               <ul style="list-style-type: none"> <li>• Overcurrent</li> <li>• Undercurrent</li> </ul> </li> <li>• Undervoltage</li> <li>• High pump room temperature</li> <li>• Phase unbalance</li> <li>• Fail to start</li> <li>• Ground fault</li> </ul>		
<b>VizITouch Operator Interface</b>	<ul style="list-style-type: none"> <li>• Embedded microcomputer with software PLC logic</li> <li>• 4.2" color touch screen (HMI technology)</li> <li>• Upgradable software</li> </ul>		<ul style="list-style-type: none"> <li>• Expandable storage</li> <li>• Multi-language</li> </ul>
<b>Operation</b>	Automatic Start	<ul style="list-style-type: none"> <li>• Start on pressure drop</li> <li>• Remote start signal from automatic device</li> </ul>	
	Manual Start	<ul style="list-style-type: none"> <li>• Start pushbutton</li> <li>• Run test pushbutton</li> <li>• Deluge valve start</li> <li>• Remote start from manual device</li> </ul>	
	Stopping	<ul style="list-style-type: none"> <li>• Manual with Stop pushbutton</li> <li>• Automatic after expiration of minimum run timer **</li> </ul>	
	Timers	Field Adjustable & Visual Countdown	<ul style="list-style-type: none"> <li>• Minimum run timer** (off delay)</li> <li>• Sequential start timer (on delay)</li> <li>• Periodic test timer</li> </ul>
	Actuation	Visual Indication	<ul style="list-style-type: none"> <li>• Pressure</li> <li>• Non-pressure</li> </ul>
	Mode		<ul style="list-style-type: none"> <li>• Automatic</li> <li>• Non-automatic</li> </ul>

\*\* Can only be used if approved by the AHJ



# Submittal Data Sheet Model GPL Electric Pump Controller

<b>A – Operational Modifications</b>	
<input type="checkbox"/> A4	Flow switch provision
<input type="checkbox"/> A8	Foam pump application w/o pressure transducer and run test solenoid valve
<input type="checkbox"/> A9	Low zone pump control function
<input type="checkbox"/> A10	Medium zone pump control function
<input type="checkbox"/> A11	High zone pump control function
<input type="checkbox"/> A13	Non-pressure actuated controller w/o pressure transducer and run test solenoid valve
<input type="checkbox"/> A16	Lockout/interlock circuit from equipment installed inside the pump room

<b>B – Additional Visual Indications</b>	
<input type="checkbox"/> B11	Built in alarm panel (120V.AC supervisory power) providing indication for: <ul style="list-style-type: none"> <li>• Audible alarm &amp; silence pushbutton for motor run, phase reversal, loss of phase.</li> <li>• Pilot lights for loss of phase &amp; supervisory power available</li> </ul>
<input type="checkbox"/> B11B	Built in alarm panel same as B11 but 220-240VAC supervisory power
<input type="checkbox"/> B19	High motor temperature c/w thermistor relay
<input type="checkbox"/> B20	High electric motor vibration
<input type="checkbox"/> B21	Ground fault
<input type="checkbox"/> B23	Flow meter valve loop open
<input type="checkbox"/> B24	High water reservoir level
<input type="checkbox"/> Bx	Additional visual indication (specify function)

<b>C – Additional Alarm Contacts (SPDT-8A-250V.AC)</b>	
<input type="checkbox"/> C1	Extra motor run
<input type="checkbox"/> C4	Periodic test
<input type="checkbox"/> C6	Low discharge pressure
<input type="checkbox"/> C7	Low pump room temperature
<input type="checkbox"/> C10	High water reservoir level
<input type="checkbox"/> C11	High electric motor temperature
<input type="checkbox"/> C12	High electric motor vibration
<input type="checkbox"/> C13	Ground fault
<input type="checkbox"/> C14	Pump on demand/automatic start
<input type="checkbox"/> C15	Pump fail to start
<input type="checkbox"/> C16	Control voltage healthy
<input type="checkbox"/> C17	Flow meter valve loop open
<input type="checkbox"/> C18	High water reservoir level
<input type="checkbox"/> C19	Emergency start
<input type="checkbox"/> C20	Manual start
<input type="checkbox"/> C21	Deluge valve start
<input type="checkbox"/> C22	Remote automatic start
<input type="checkbox"/> C23	Remote manual start
<input type="checkbox"/> C24	High pump room temperature
<input type="checkbox"/> Cx	Additional alarm contact (specify function)

<b>D - Miscellaneous</b>	
<input type="checkbox"/> D1A	Low suction pressure transducer for fresh water rated at 0-600PSI with visual indication and alarm contact
<input type="checkbox"/> D10	Omit mounting feet (when applicable)
<input type="checkbox"/> D13A	High withstand rating (fire pump section only) up to 208V to 480V = 65KA / 600V = 25KA
<input type="checkbox"/> D14	Anti-condensation heater & thermostat (fire pump section only)
<input type="checkbox"/> D14A	Anti-condensation heater & humidistat (fire pump section only)
<input type="checkbox"/> D14B	Anti-condensation heater & thermostat & humidistat (fire pump section only)
<input type="checkbox"/> D15	Tropicalization
<input type="checkbox"/> D18	CE Mark with factory certificate
<input type="checkbox"/> D19	French labelling
<input type="checkbox"/> D20	Spanish labelling
<input type="checkbox"/> D21	Other languages
<input type="checkbox"/> D26	Modbus RTU provision
<input type="checkbox"/> D26A	Modbus TCP/IP provision
<input type="checkbox"/> D27	Motor heater connection (external single phase power source and heater on/off contact)
<input type="checkbox"/> D27A	Motor heater connection (internal single phase power source and heater on/off contact)
<input type="checkbox"/> D28	Customized drawing set
<input type="checkbox"/> D34	Field programmable I/O board - 8 Input / 5 output
<input type="checkbox"/> D35	Field programmable I/O board - 8 Input / 10 output
<input type="checkbox"/> D36	Redundant pressure transducer for fresh water rated for 0-600PSI
<input type="checkbox"/> D37	Window kit for operator interface

**Note: Options chosen from this page are not electrically represented on the wiring schematics in this submittal package.**

ViZi Touch Operator Interface

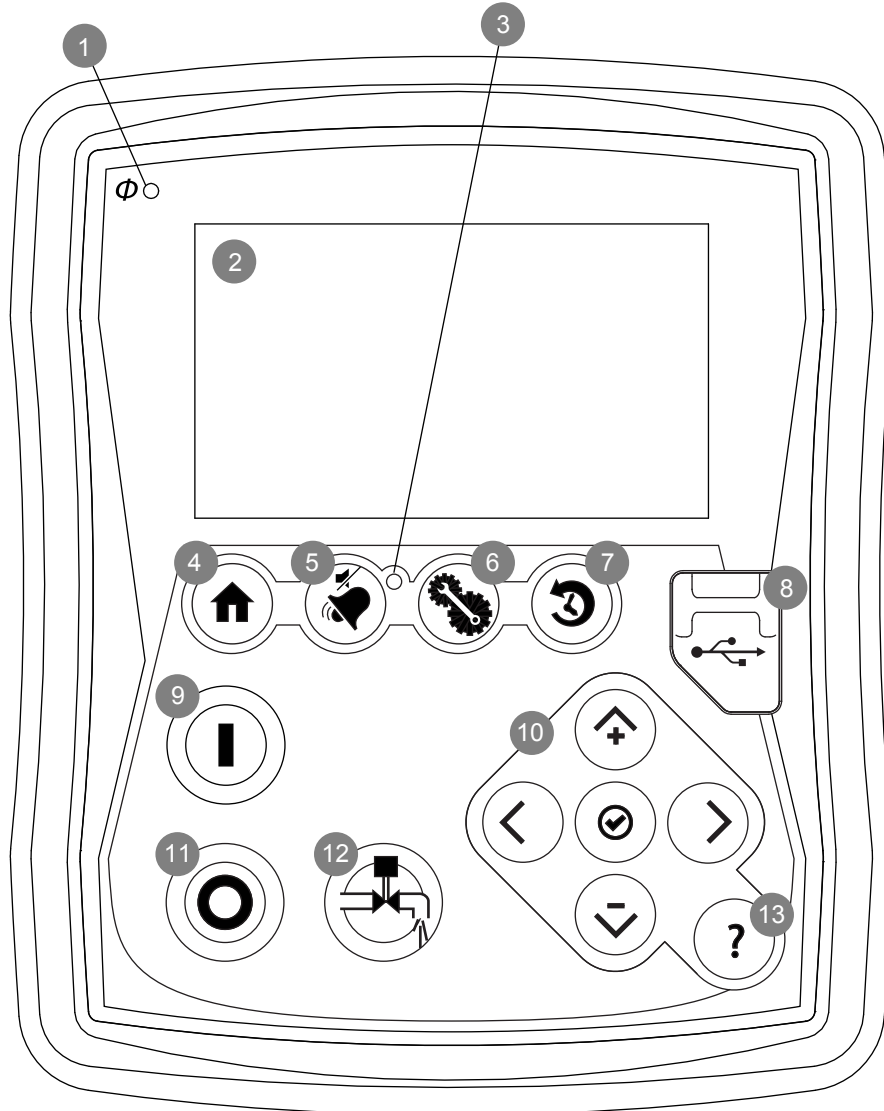

- |                               |                                |
|-------------------------------|--------------------------------|
| 1 - Power LED                 | 8 - USB port                   |
| 2 - Color touch screen        | 9 - START button               |
| 3 - Alarm LED                 | 10 - Contextual navigation pad |
| 4 - HOME page button          | 11 - STOP button               |
| 5 - ALARM page button         | 12 - RUN TEST button           |
| 6 - CONFIGURATION page button | 13 - HELP button               |
| 7 - HISTORY page button       |                                |

# LIMITED SERVICE PUMP CONTROLLER

MODEL : GPL

## 1 AND 3 PHASES

Dimensions

BUILT TO THE LATEST EDITION OF THE NFPA20 STANDARD

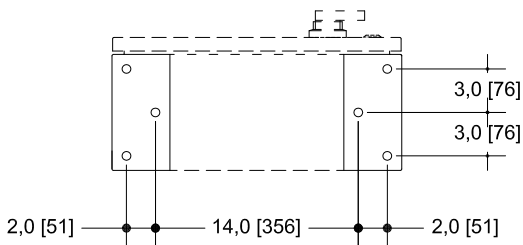
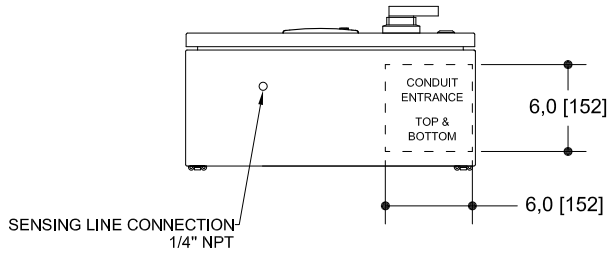
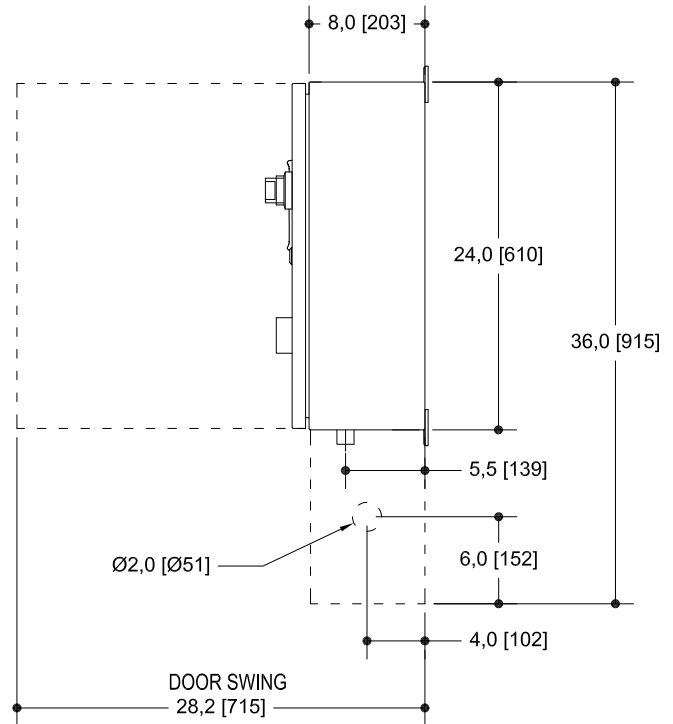
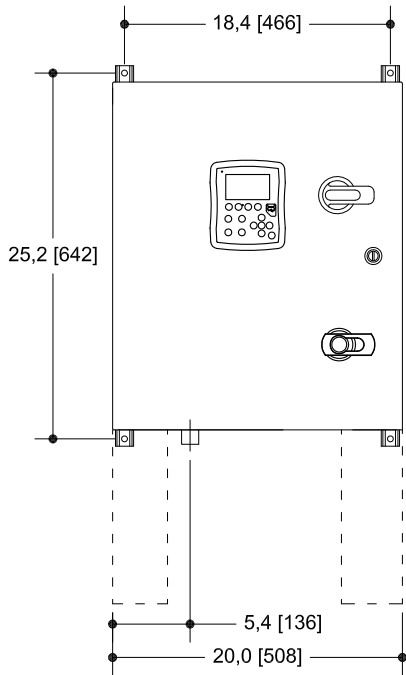

**NOTES :**

- ALL DIMENSIONS ARE IN INCHES (MILLIMETERS).
- PAINT : TEXTURED RED RAL 3002.
- USE WATERTIGHT CONDUIT CONNECTOR ONLY.
- PROTECT EQUIPMENT AGAINST DRILLING CHIPS.
- AMBIENT TEMPERATURE : BETWEEN 41°F (5°C) AND 104°F (40°C).

VOLT/Hz	HP RATING		WITHSTAND RATING [kA] RMS	
	MIN HP	MAX HP	STANDARD	HIGH (OPT. D13)
<b>1 PHASE</b>				
200-208 / 60	3 HP	15 HP	65kA	65kA
230-240 / 50-60	3 HP	15 HP	65kA	65kA
<b>3 PHASES</b>				
200-208 / 60	3 HP	30 HP	65kA	65kA
230-240 / 50-60	3 HP	30 HP	65kA	65kA
380-415 / 50-60	3 HP	30 HP	25kA	65kA
440-480 / 50-60	3 HP	30 HP	25kA	65kA
575-600 / 60	3 HP	30 HP	18kA	25kA

NEMA 2 ENCLOSURE (STD)

SHIPPING WEIGHT  
100 LBS - 46 KG

WALL MOUNT. (STANDARD)  
FEET MOUNT.(OPT. D10)

Drawing for information only.  
Manufacturer reserves the right to modify this drawing without notice.  
Contact manufacturer for "As Built" drawing.



REV.	DATE	DESCRIPTION	APP.
0.	12/01/10	FIRST ISSUE	

DRAWING No.  
DES.  
VER.  
APP.  
GPL-DI100 / E

# ELECTRIC FIRE PUMP CONTROLLER LIMITED SERVICE CONTROLLER 3 PHASES

MODEL :GPL

Wiring schematic

BUILT TO THE LATEST EDITION OF THE NFPA20 STANDARD

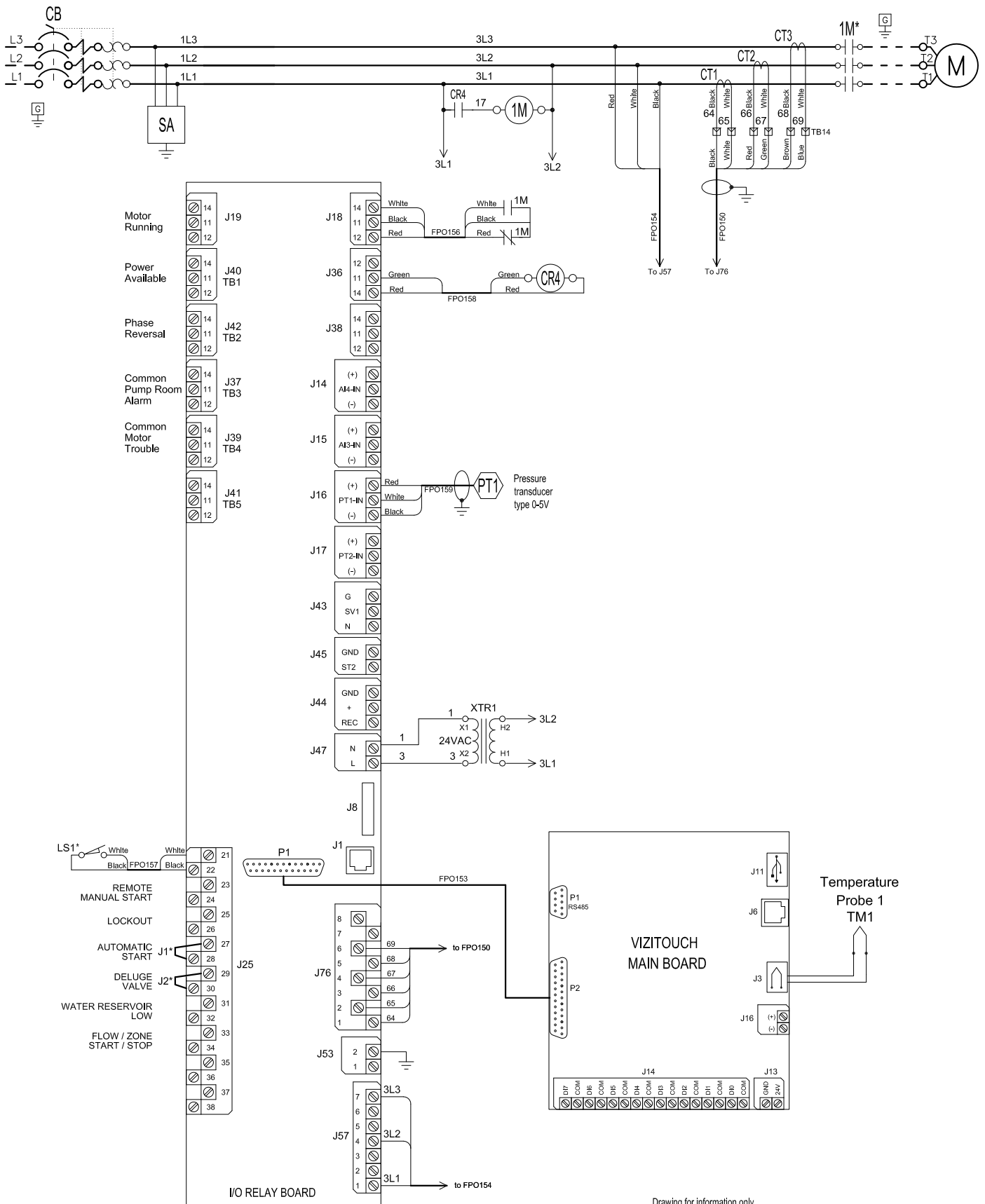

Drawing for information only.  
Manufacturer reserves the right to modify this drawing without notice.  
Contact manufacturer for "As Built" drawing.

\* REMOVE JUMPER TO USE THIS FEATURE

\* Contact closed when Emergency Start is in ON position

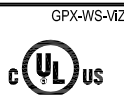

REV.	DATE	DESCRIPTION	APP.
0.	12/01/09	FIRST ISSUE	DES.

DES.	VER.	Drawing No.
DES.	VER.	GPL-WS501 /E

Power Terminals  
Model : GPL 3 PHASES

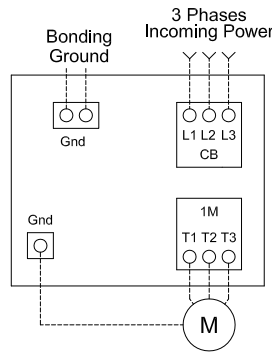

**Circuit Breaker (CB) Field Wiring according to Bending Space (AWG or MCM). TERMINALS L1 - L2 - L3**

Bending Space	5 " (127 mm)						
HP Voltage	5	7.5	10	15	20	25	30
208	1x (10 to 1/0)	1x (8 to 1/0)	1x (8 to 1/0)	1x (6 to 1/0)	1x (4 to 1/0)	1x (3 to 1/0)	1x (2 to 1/0)
220 to 240	1x (10 to 1/0)	1x (10 to 1/0)	1x (8 to 1/0)	1x (6 to 1/0)	1x (4 to 1/0)	1x (4 to 1/0)	1x (3 to 1/0)
380 to 416	1x (10 to 1/0)	1x (10 to 1/0)	1x (10 to 1/0)	1x (8 to 1/0)	1x (8 to 1/0)	1x (6 to 1/0)	1x (6 to 1/0)
440 to 480	1x (10 to 1/0)	1x (10 to 1/0)	1x (10 to 1/0)	1x (10 to 1/0)	1x (8 to 1/0)	1x (8 to 1/0)	1x (6 to 1/0)
600	1x (10 to 1/0)	1x (10 to 1/0)	1x (10 to 1/0)	1x (10 to 1/0)	1x (10 to 1/0)	1x (8 to 1/0)	1x (8 to 1/0)

**Wiring Size for motor connection for Model PGL (AWG or MCM). TERMINALS T1 - T2 - T3**

HP Voltage	5	7.5	10	15	20	25	30
208	1x (10)	1x (10)	1x (8 to 2)	1x (6 to 2)	1x (4 to 1/0)	1x (3 to 1/0)	1x (2 to 1/0)
220 to 240	1x (12 to 10)	1x (10)	1x (8 to 2)	1x (6 to 2)	1x (4 to 1/0)	1x (4 to 1/0)	1x (3 to 1/0)
380 to 416	1x (14 to 10)	1x (12 to 10)	1x (8 to 2)	1x (8 to 2)	1x (8 to 2)	1x (6 to 2)	1x (6 to 1/0)
440 to 480	1x (14 to 10)	1x (14 to 10)	1x (12 to 10)	1x (10)	1x (8 to 2)	1x (8 to 2)	1x (6 to 2)
600	1x (14 to 10)	1x (14 to 10)	1x (14 to 10)	1x (12 to 10)	1x (10)	1x (8 to 2)	1x (8 to 2)

Notes:

- 1 - For proper wire sizing, refer to NFPA70 and NEC (USA) or CEC (Canada) or local code.
- 2 - Controller suitable for service entrance in USA.
- 3 - For more accurate motor connections refer to motor manufacturer or motor nameplate.
- 4 - Controller is phase sensitive. Incoming lines must be connected in ABC sequence.

Drawing for information only.  
Manufacturer reserves the right to modify this drawing without notice.  
For drawing for approval or installation, please contact manufacturer.



REV.	DATE	DESCRIPTION	APP.	Drawing No.
0.	12/01/10	FIRST ISSUE	VER.	GPL-TD501 1/2 /E
			APP.	

### Remote Alarm Terminals (I/O board)

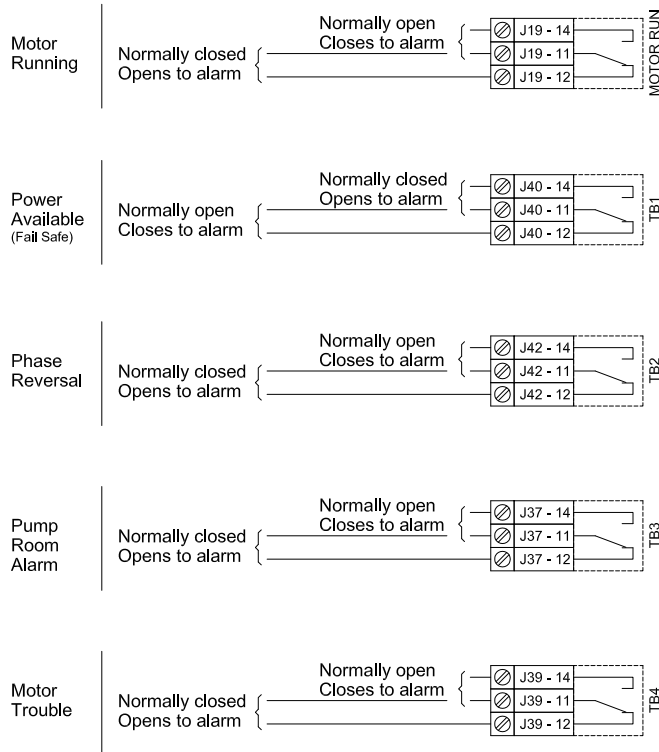

### Control Terminals (I/O board)

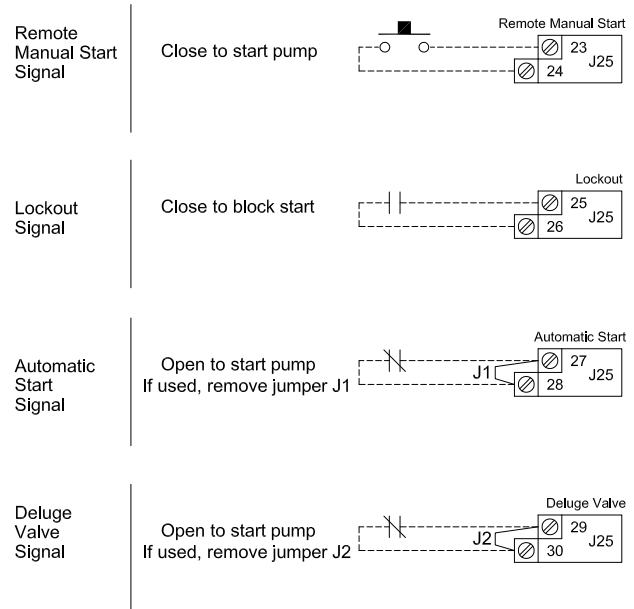

### Filed Connections for External Devices (I/O board)

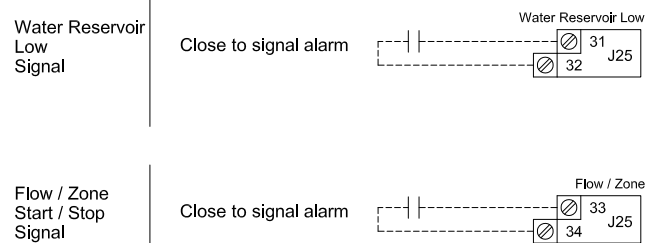

Drawing for information only.  
Manufacturer reserves the right to modify this drawing without notice.  
For drawing for approval or installation, please contact manufacturer.