

Electric Fire Pump Controller

Reduced Voltage / Wye Delta (Open Transition)

Dimension

Model: GFY

Built as per NFPA 20-2013 standard



REV.	DESCRIPTION	DD/MM/YY
0.	FIRST ISSUE	04/02/16
1.	TITLE BLOCK INFORMATION CHANGED	11/11/16
2.	REVISED LOGO	18/06/18

Drawing No. GFY-D1502 /E

GFX-S1-VIZI

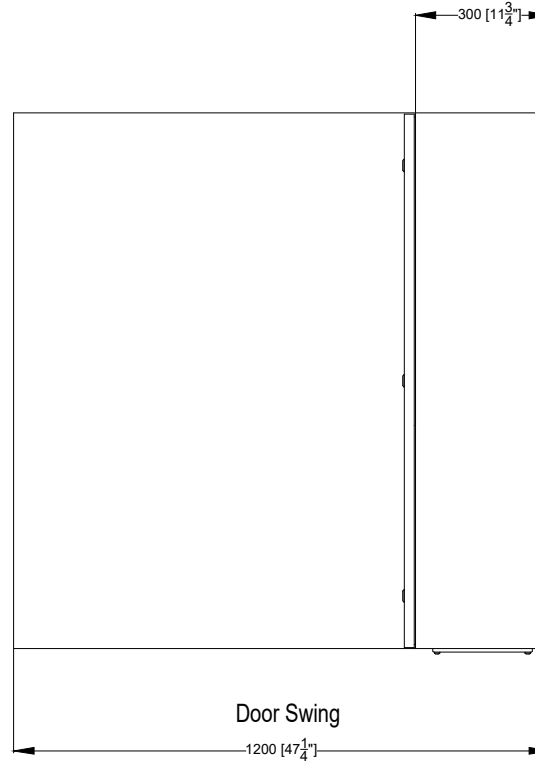
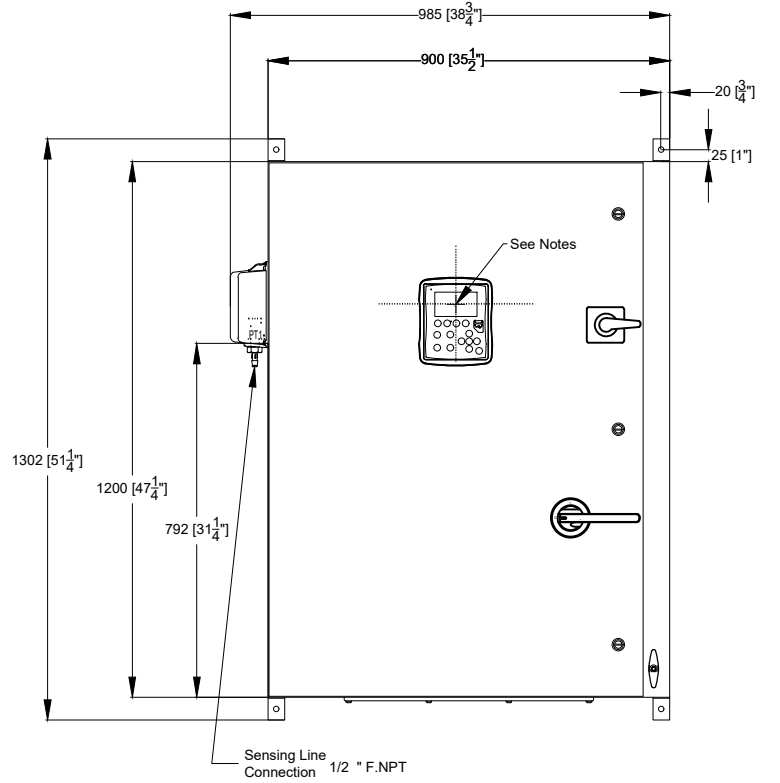

Power Table

Voltage	Min	Max
220 - 240	125 HP	200 HP
	75 kW	132 kW
380 - 400 - 415	200 HP	350 HP
	132kW	250 kW

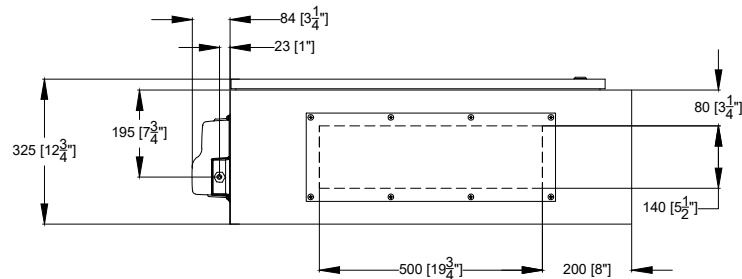

Notes:

- IP55 assembly.
- All dimensions are in millimeters [Inches].
- Center of ViZiTouch screen: 880 [34-3/4]" from bottom.
- Paint: textured red RAL 3002.
- Bottom conduit entrance through removable gland plate recommended.
- Use watertight conduit and connectors only.
- Protect equipment against drilling chips.
- Drawing for information only.

Manufacturer reserves the right to modify this drawing without notice.
Contact manufacturer for "As Built" drawing.

