



TORNATECH

Project: _____

Customer: _____

Engineer: _____

Pump Manufacturer: _____

Technical Data Submittal Document

GfX Series

Electric Fire Pump Controller



Contents:

Data Sheets

Dimensional Data

Wiring Schematics

Field Connections

Note: The drawings included in this package are for controllers covered under our standard offering. Actual AS BUILT drawings may differ from what is shown in this package.



April 2024

Select starting method

Model GFA Across the line

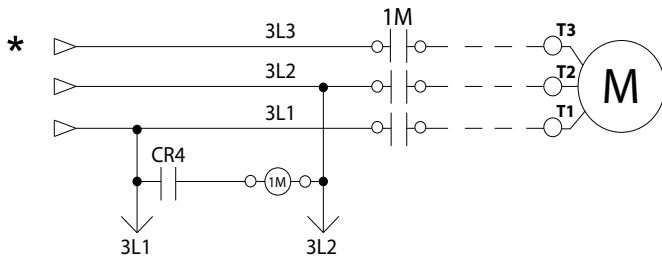

Model GFY Wye-Delta Open

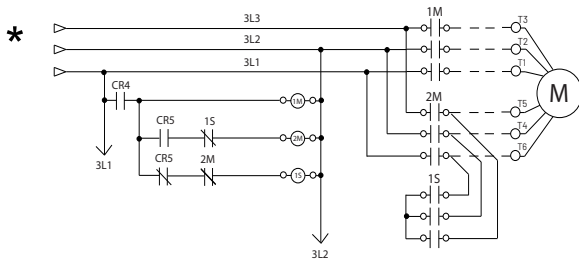

Model GFW Wye-Delta Closed

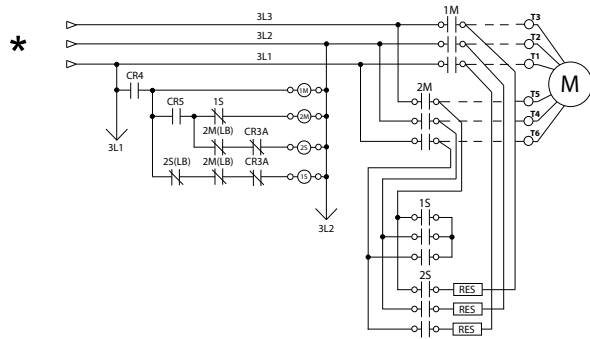

Standard & Certification	Built to NFPA 20		
	CE & UKCA Mark	Various EN, IEC & CEE directives and standards	
	Built in U.A.E	Built in Europe	
	CE Mark (only) Option	Supplied as Standard	
Enclosure	Protection Rating: Standard: IP55		
	Optional		
	NEMA 12	NEMA 4X-304 sst painted	IP65
	NEMA 3	NEMA 4X-304 sst brushed finish	
	NEMA 3R	NEMA 4X-316 sst painted	IP66
	NEMA 4	NEMA 4X-316 sst brushed finish	
Accessories • Bottom entry gland plate		Paint Specifications • Red RAL3002 • Powder coating • Glossy textured finish	

*From normal incoming power through Disconnecting Means (IS/CB)



<p>Disconnecting Means</p>	<ul style="list-style-type: none"> • Isolating switch and circuit breaker: Isolating switch rated not less than 115% of motor full load current Circuit breaker continuous rating not less than 115% of motor full load current Overcurrent sensing non-thermal type, magnetic only Instantaneous trip setting of not more than 20 times the motor full load current • Individual operating handles 																					
<p>Emergency Start Handle</p>	<ul style="list-style-type: none"> • Flange mounted • Pull and latch activation • Integrated limit switch • Across the line start (direct on line) 																					
<p>Locked Rotor</p>	<ul style="list-style-type: none"> • Operate shunt trip to open circuit breaker • Factory set at 600% of motor full load current • Trip between 8 and 20 seconds 																					
<p>Electrical Readings</p>	<ul style="list-style-type: none"> • Voltage phase to phase (normal power) • Amperage of each phase when motor is running 																					
<p>Pressure Readings</p>	<ul style="list-style-type: none"> • Continuous system pressure display • Cut-in and Cut-out pressure settings 																					
<p>Pressure and Event recorder</p>	<ul style="list-style-type: none"> • Pressure readings with date stamp • Event recording with date stamp • Under regular maintained operation, events are stored in memory for the life of the controller. • Data viewable on operator interface display screen 																					
<p>Pressure Sensing</p>	<ul style="list-style-type: none"> • Pressure transducer for fresh water application • Pressure sensing line connection 1/2" Female NPT • Rated for 0-500PSI working pressure (standard display at 0-300PSI) • Externally mounted with protective cover 																					
<p>Visual Indications & Alarms</p>	<table border="0"> <tr> <td>• Power available</td> <td>• Phase unbalance</td> <td>• Deluge valve start</td> </tr> <tr> <td>• Phase reversal</td> <td>• Locked rotor</td> <td>• Remote automatic start</td> </tr> <tr> <td>• Motor run</td> <td>• Fail to start</td> <td>• Remote manual start</td> </tr> <tr> <td>• Pump room alarm</td> <td>• Low discharge pressure</td> <td>• Overcurrent</td> </tr> <tr> <td>• Motor trouble</td> <td>• Pump on demand/Automatic start</td> <td>• Undercurrent</td> </tr> <tr> <td>• Phase loss</td> <td>• Emergency start</td> <td>• Undervoltage</td> </tr> <tr> <td>• Low water level</td> <td>• Manual start</td> <td>• Overvoltage</td> </tr> </table>	• Power available	• Phase unbalance	• Deluge valve start	• Phase reversal	• Locked rotor	• Remote automatic start	• Motor run	• Fail to start	• Remote manual start	• Pump room alarm	• Low discharge pressure	• Overcurrent	• Motor trouble	• Pump on demand/Automatic start	• Undercurrent	• Phase loss	• Emergency start	• Undervoltage	• Low water level	• Manual start	• Overvoltage
• Power available	• Phase unbalance	• Deluge valve start																				
• Phase reversal	• Locked rotor	• Remote automatic start																				
• Motor run	• Fail to start	• Remote manual start																				
• Pump room alarm	• Low discharge pressure	• Overcurrent																				
• Motor trouble	• Pump on demand/Automatic start	• Undercurrent																				
• Phase loss	• Emergency start	• Undervoltage																				
• Low water level	• Manual start	• Overvoltage																				
<p>Remote Alarm Contacts</p>	<p>SPDT-8A-250V.AC</p> <ul style="list-style-type: none"> • Power available • Phase reversal • Motor run • Common pump room alarm <ul style="list-style-type: none"> • Overvoltage • Undervoltage • Phase unbalance • Common motor trouble <ul style="list-style-type: none"> • Overcurrent • Undercurrent • Fail to start 																					
<p>Ambient Temperature Rating</p>	<p>Standard 4°C to 40°C / 39°F to 104°F</p> <p>Optional 4°C to 55°C / 39°F to 131°F</p>																					



ViZiTouch V2.1 Operator Interface	<ul style="list-style-type: none"> • Embedded microcomputer with software PLC logic • 7.0" color touch screen (HMI technology) • Upgradable software • Multi-language 		
Audible Alarm	Alarm buzzer - 85dB at 3 meters		
Operation	Automatic Start	<ul style="list-style-type: none"> • Start on pressure drop • Remote start signal from automatic device 	
	Manual Start	<ul style="list-style-type: none"> • Start pushbutton • Run test pushbutton • Deluge valve start • Remote start from manual device 	
	Stopping	<ul style="list-style-type: none"> • Manual with Stop pushbutton • Automatic after expiration of minimum run timer ** 	
	Timers	Field Adjustable & Visual Countdown	<ul style="list-style-type: none"> • Minimum run timer ** (off delay) • Sequential start timer (on delay) • Manual test timer
	Actuation	Visual Indication	<ul style="list-style-type: none"> • Pressure • Non-pressure
	Mode		<ul style="list-style-type: none"> • Automatic • Non-automatic

** Can only be used if approved by the AHJ



A13	Non-pressure actuated controller w/o pressure transducer and run test solenoid valve
A16	Lockout/interlock circuit from equipment installed inside the pump room
B11B	Built in alarm panel (220VAC supervisory power) providing indication for: <ul style="list-style-type: none"> • Audible alarm & silence pushbutton for motor run • Phase reversal • Loss of phase • Pilot lights for loss of phase & supervisory power available
B19A	High motor temperature c/w thermostat relay and alarm contacts (Form C-SPDT)
B19B	High motor temperature c/w PT100 relay and alarm contacts (Form C-SPDT)
B21	Ground fault alarm indication c/w visual indication and alarm contact (Form C-SPDT)
C1	Extra motor run alarm contact (Form C-SPDT)
C4	Periodic test alarm contact (Form C-SPDT)
C6	Low discharge (system) pressure alarm contact (Form C-SPDT)
C7	Low pump room temperature alarm contact (Form C-SPDT)
C10	Low water level alarm contact (Form C-SPDT)
C11	High motor temperature alarm contact (Form C-SPDT)
C12	High vibration c/w visual indication and alarm contact (Form C-SPDT)
C14	Pump on demand / automatic start alarm contact (Form C-SPDT)
C15	Pump fail to start alarm contact (Form C-SPDT)
C16	Control voltage healthy alarm contact (Form C-SPDT)
C17	Flow meter loop valve open c/w visual indication and alarm contact (Form C-SPDT)
C18	High water level c/w visual indication and alarm contact (Form C-SPDT)
C19	Emergency start alarm contact (Form C-SPDT)

C20	Manual start alarm contact (Form C-SPDT)
C21	Deluge valve start alarm contact (Form C-SPDT)
C22	Remote automatic start alarm contact (Form C-SPDT)
C23	Remote manual start alarm contact (Form C-SPDT)
C24	High pump room temperature alarm contact (Form C-SPDT)
Cx	Other addition alarm contact alarm contact (Form C-SPDT) (specify function)
D1	Low suction pressure transducer for fresh water rated for 0-300psi with visual indication and alarm contact
D1A	Low suction pressure transducer for sea water rated for 0-300psi with visual indication and alarm contact
D5E	Addition of run test solenoid valve for fresh water rated for 0-500psi
D5F	Addition of run test solenoid valve for sea water rated for 0-500psi
D14	Anti-condensation heater & thermostat
D14A	Anti-condensation heater & humidistat
D14B	Anti-condensation heater & thermostat & humidistat
D15	Tropicalization
D26A	Modbus TCP/IP provision
D27	Motor heater connection (external single phase power source and heater on/off contact)
D27A	Motor heater connection (internal single phase power source and heater on/off contact, specify WATTS)
D34A	Field programmable i/o board - 5 input /5 output (NOTE: If more than 5 input or 5 output are required, please order this option as many times as required (max.8)
D36	Redundant pressure transducer for fresh water rated for 0-500psi
D36A	Redundant pressure transducer for sea water rated for 0-500psi

Note: Options chosen from this page are not electrically represented on the wiring schematics in this submittal package.

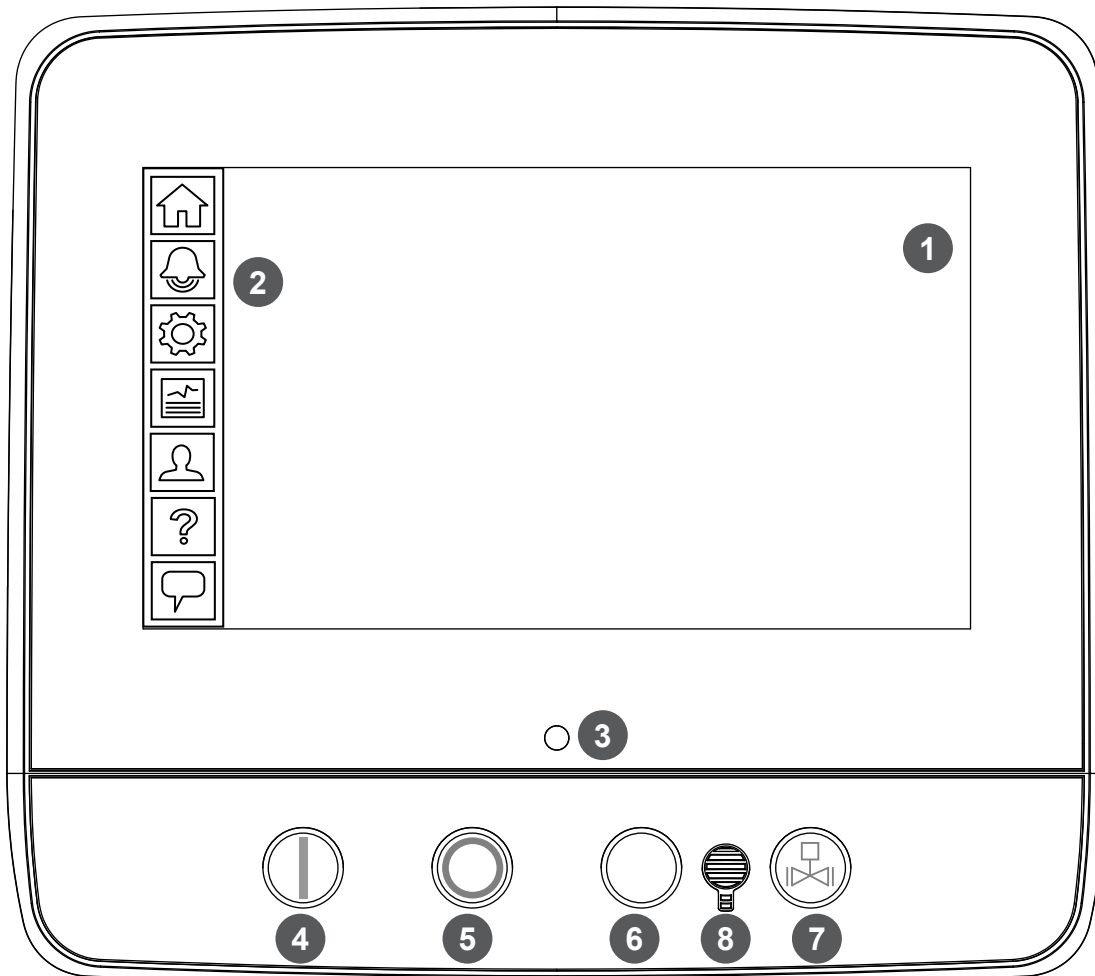

L01	Other language and English (bilingual)
L02	French
L03	Spanish
L04	German
L05	Italian
L06	Polish
L07	Romanian
L08	Hungarian
L09	Slovakian
L10	Croatian
L11	Czech
L12	Portuguese
L13	Dutch
L15	Turkish
L16	Swedish
L21	Danish
L25	Chinese
L28	Finnish
L29	Norwegian
L30	Vietnamese

ViZiTouch V2.1 Operator Interface

- | | |
|------------------------|--------------------------|
| 1 - Color touch screen | 3 - Power LED (3 colors) |
| 2 - Onscreen menu | 4 - START button |
| • HOME page | 5 - STOP button |
| • ALARM page | 6 - Not Used |
| • CONFIGURATION page | 7 - RUN TEST button |
| • HISTORY page | 8 - Alarm buzzer |
| • SERVICE page | |
| • MANUAL page | |
| • LANGUAGES page | |



© Tornatech, Inc. Not for construction.
Subject to change without notice.

BY		DD/MM/YY
DRAWN BY	ACD	31/01/24
FINAL APPROVAL	FC	01/02/24

ELECTRIC FIRE PUMP CONTROLLER

MODEL: GFA/GFY

BUILT TO NFPA20



DRAWING NUMBER
GFX-D1810/E
DWG REV. 0
SHEET 1 OF 1

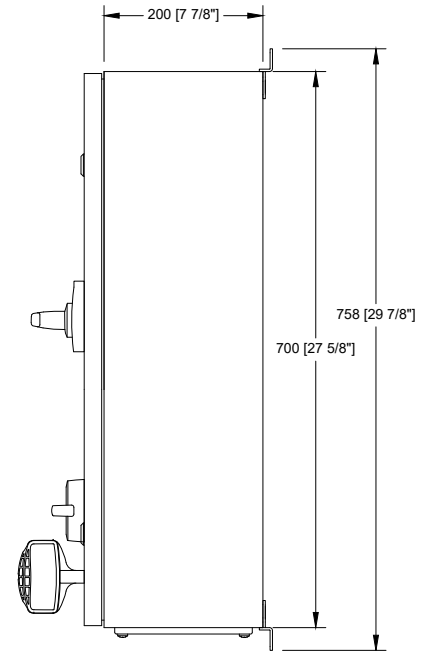
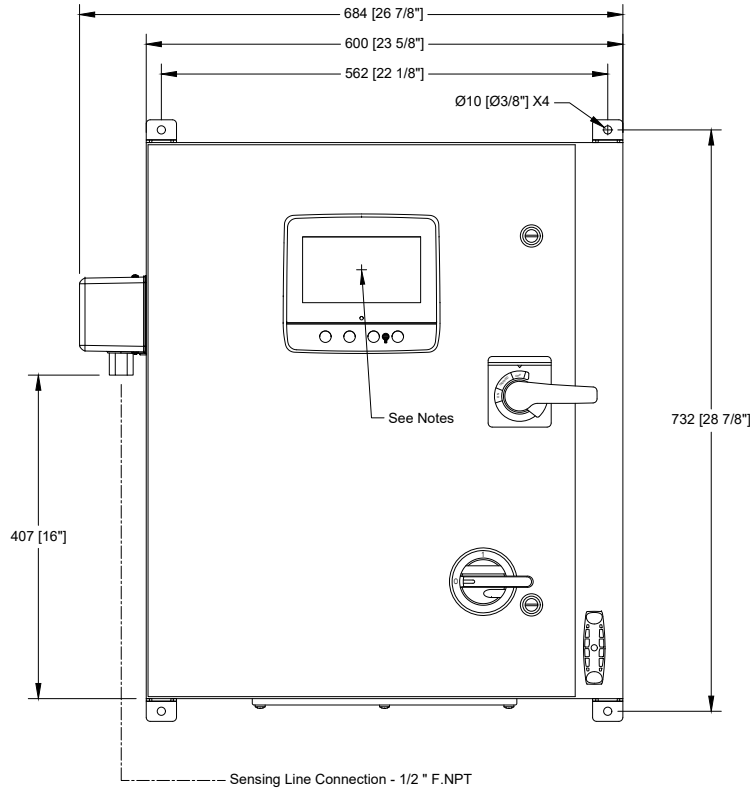

Voltage / Power Table		
Voltage	Min	Max
220 - 240	5 HP	40 HP
	4 kW	22 kW
380 - 400 - 415	5 HP	60 HP
	4 kW	45 kW

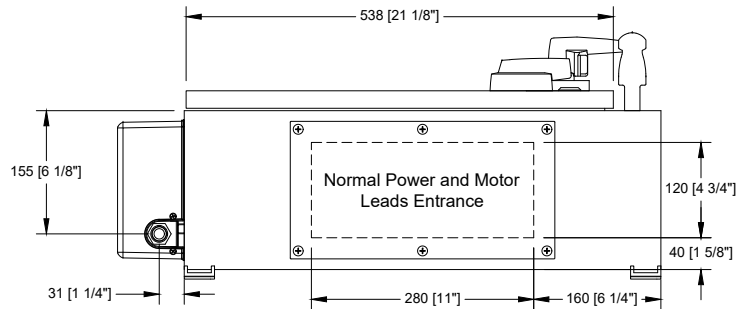

Notes:

- Standard: IP55
- Standard paint : textured red RAL 3002.
- All dimensions are in millimeters [inches].
- Center of screen: 540 [21 1/4"] from bottom.
- Bottom conduit entrance through removable gland plate recommended.
- Use watertight conduit and connector only.
- Protect equipment against drilling chips.
- Door swing equal to door width.



© Tornatech, Inc. Not for construction.
Subject to change without notice.

BY		DD/MM/YY
DRAWN BY	ACD	31/01/24
FINAL APPROVAL	FC	01/02/24

ELECTRIC FIRE PUMP CONTROLLER REDUCED VOLTAGE / WYE DELTA (OPEN TRANSITION)

MODEL:GFY

BUILT TO NFPA20



DRAWING NUMBER	GFY-WS800/E
DWG REV. 1	
SHEET 1 OF 2	

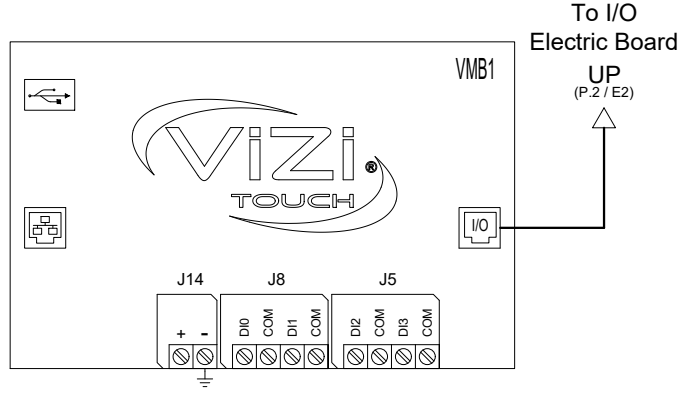
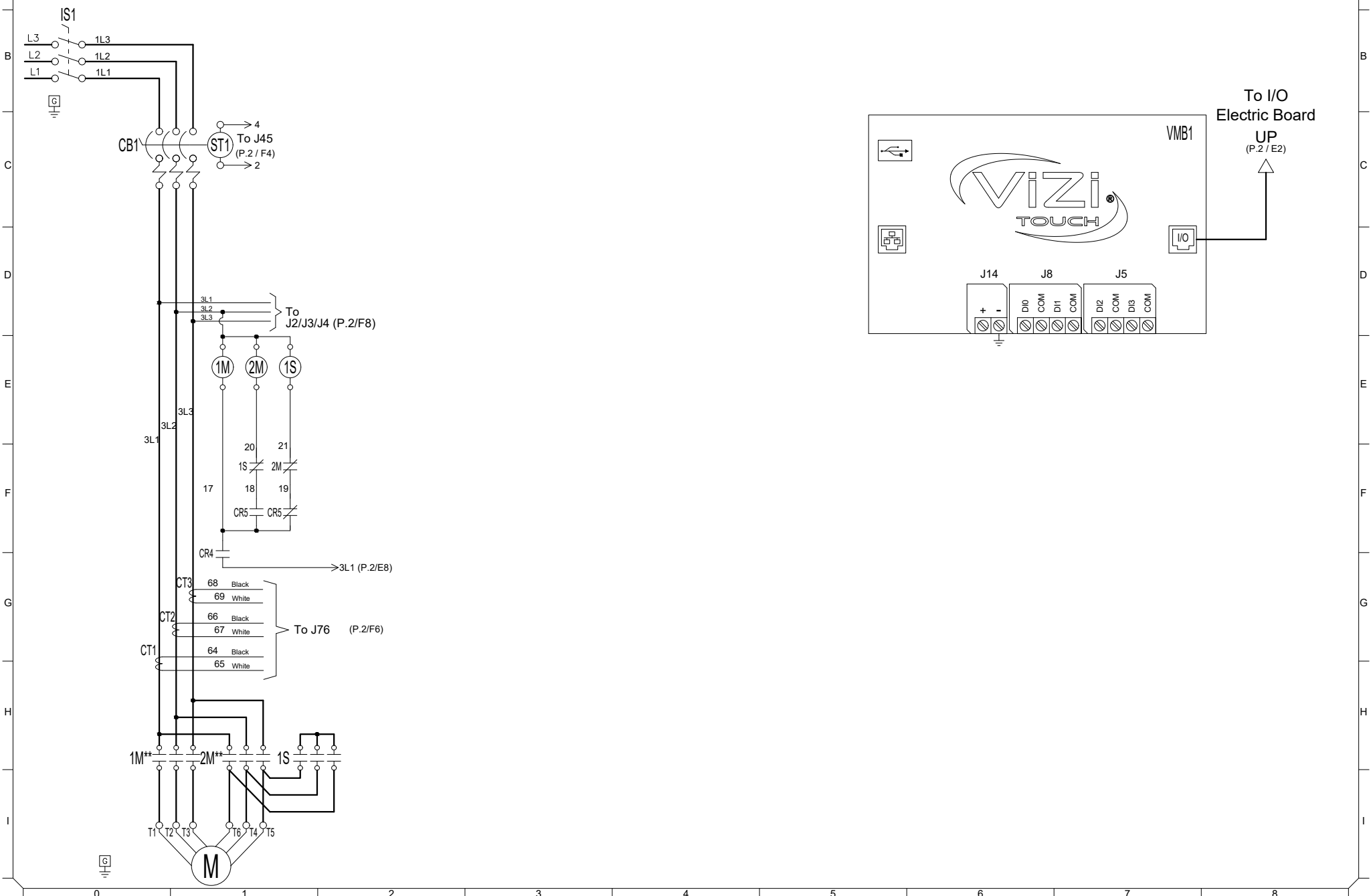



© Tornatech, Inc. Not for construction.
Subject to change without notice.

BY DD/MM/YY	
DRAWN BY	ACD 31/01/24
FINAL APPROVAL	FC 01/02/24

ELECTRIC FIRE PUMP CONTROLLER REDUCED VOLTAGE / WYE DELTA (OPEN TRANSITION)

MODEL:GFY

BUILT TO NFPA20



DRAWING NUMBER
GFY-WS800/E
DWG REV. 1
SHEET 2 OF 2

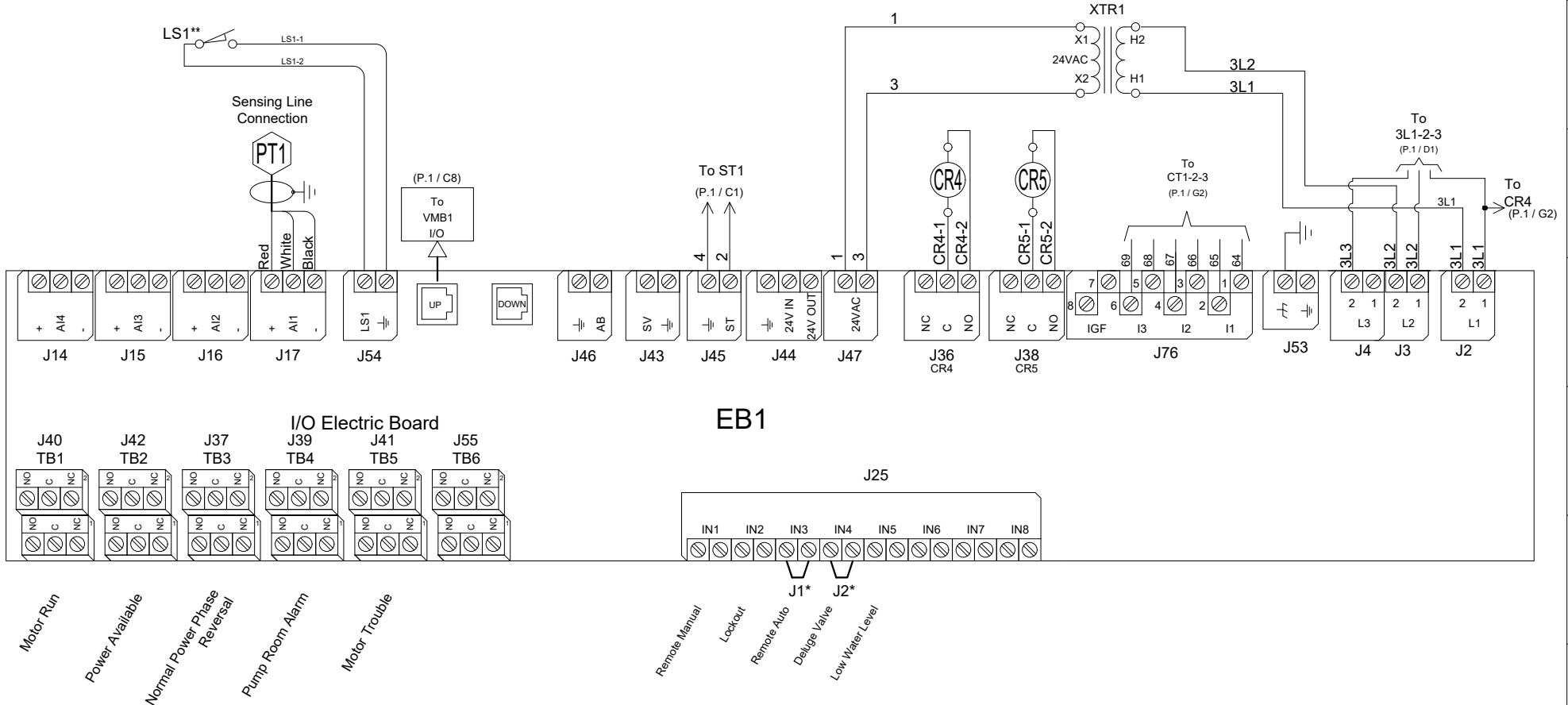

* Remove jumper to use this feature
** Contact closes when emergency start is in "ON" position



BY DD/MM/YY

DRAWN BY ACD 31/01/24

FINAL APPROVAL FC 01/02/24

ELECTRIC FIRE PUMP CONTROLLER

MODEL:GFX

BUILT TO NFPA20



DRAWING NUMBER
GFX-TD803/E

DWG REV. 0

SHEET 1 OF 1

© Tornatech, Inc. Not for construction.
Subject to change without notice.

Field Connections

Terminals Wire Size:
24 - 12 AWG
0.5 Nm

- Remote Manual
- Lockout
- Remote Auto
- Deluge Valve
- Low Water Level

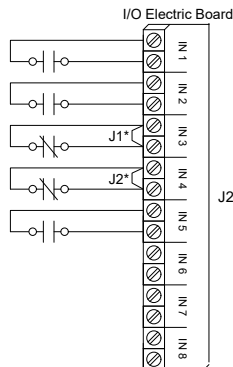

Network Connections

Terminals Wire Size:
Shielded Female Connector RJ45

Modbus TCP/IP RJ45

Located on Main Board



Alarm Contacts

Terminals Wire Size:
24 - 12 AWG
0.5 Nm

Motor Run

Power Available

Normal Power Phase Reversal

Pump Room Alarm**

Motor Trouble**

(Field Programmable****)

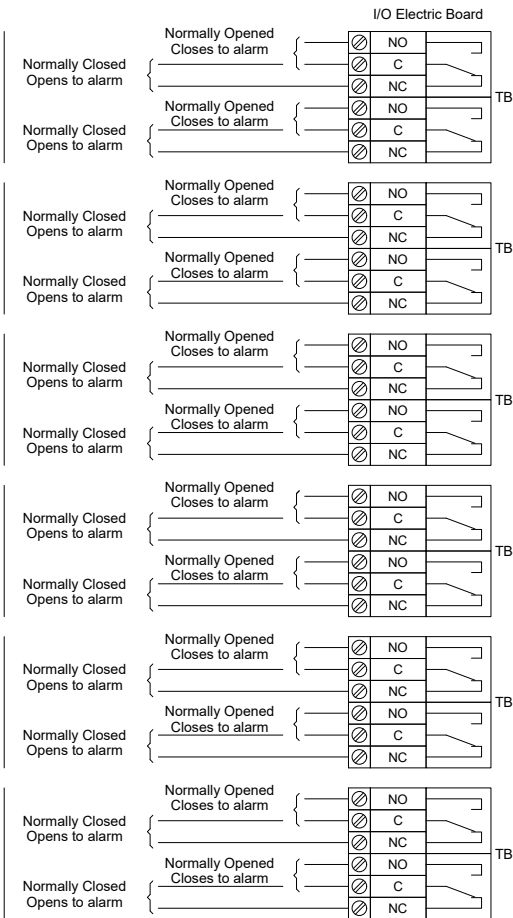

Power Terminals

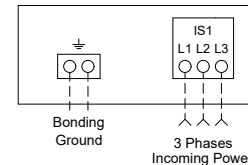

Motor Terminals

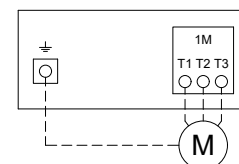

Model:GFA

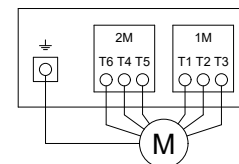

Model:GFY

* Remove jumper to use this feature
** Re-assignable