



# TORNATECH

Project: \_\_\_\_\_

Customer: \_\_\_\_\_

Engineer: \_\_\_\_\_

Pump Manufacturer: \_\_\_\_\_

## Technical Data Submittal Document

### Model GFY

Wye-delta Open  
Electric Fire Pump Controller



#### Contents:

Data Sheets

Dimensional Data

Wiring Schematics

Field Connections

Note: The drawings included in this package are for controllers covered under our standard offering. Actual AS BUILT drawings may differ from what is shown in this package.



February 2020

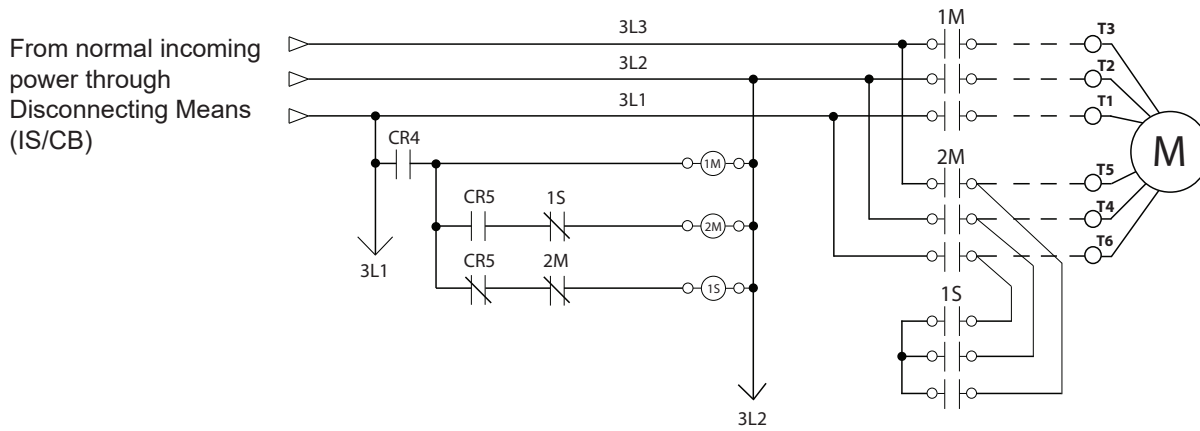

<b>Standard &amp; Certification</b>	Built to NFPA 20 (latest edition)	
	☐ CE Mark: Various EN, IEC & CEE directives and standards	
<b>Enclosure</b>	<b>Protection Rating</b> IP55	
	<b>Accessories</b> • Bottom entry gland plate	<b>Paint Specifications</b> • Red RAL3002 • Powder coating • Glossy textured finish
<b>Disconnecting Means</b>	<ul style="list-style-type: none"> <li>• Isolating switch and circuit breaker: Isolating switch rated not less than 115% of motor full load current Circuit breaker continuous rating not less than 115% of motor full load current Overcurrent sensing non-thermal type, magnetic only Instantaneous trip setting of not more than 20 times the motor full load current</li> <li>• Individual operating handles</li> </ul>	
<b>Emergency Start Handle</b>	<ul style="list-style-type: none"> <li>• Flange mounted</li> <li>• Pull and latch activation</li> <li>• Integrated limit switch</li> <li>• Across the line start (direct on line)</li> </ul>	
<b>Locked Rotor</b>	<ul style="list-style-type: none"> <li>• Operate shunt trip to open circuit breaker</li> <li>• Factory set at 600% of motor full load current</li> <li>• Trip between 8 and 20 seconds</li> </ul>	
<b>Electrical Readings</b>	<ul style="list-style-type: none"> <li>• Voltage phase to phase (normal power)</li> <li>• Amperage of each phase when motor is running</li> </ul>	
<b>Pressure Readings</b>	<ul style="list-style-type: none"> <li>• Continuous system pressure display</li> <li>• Cut-in and Cut-out pressure settings</li> </ul>	



<b>Pressure and Event recorder</b>	<ul style="list-style-type: none"> <li>• Pressure readings with date stamp</li> <li>• Event recording with date stamp</li> <li>• Under regular maintained operation, events can be stored in memory for up to 5 years.</li> <li>• Data viewable on operator interface display screen</li> </ul>		
<b>Pressure Sensing</b>	<ul style="list-style-type: none"> <li>• Pressure transducer for fresh water application</li> <li>• Pressure sensing line connection 1/2" Female NPT</li> <li>• Rated for 0-500PSI working pressure (calibrated at 0-300psi)</li> <li>• Externally mounted with protective cover</li> </ul>		
<b>Visual Indications &amp; Alarms</b>	<ul style="list-style-type: none"> <li>• Power available</li> <li>• Phase reversal</li> <li>• Motor run</li> <li>• Pump room alarm</li> <li>• Motor trouble</li> <li>• Phase loss</li> <li>• Low water level</li> </ul>	<ul style="list-style-type: none"> <li>• Phase unbalance</li> <li>• Locked rotor</li> <li>• Fail to start</li> <li>• Low discharge pressure</li> <li>• Pump on demand/Automatic start</li> <li>• Emergency start</li> <li>• Manual start</li> </ul>	<ul style="list-style-type: none"> <li>• Deluge valve start</li> <li>• Remote automatic start</li> <li>• Remote manual start</li> <li>• Overcurrent</li> <li>• Undercurrent</li> <li>• Undervoltage</li> <li>• Overvoltage</li> </ul>
<b>Remote Alarm Contacts</b>	SPDT-8A-250V.AC <ul style="list-style-type: none"> <li>• Power available</li> <li>• Phase reversal</li> <li>• Motor run</li> <li>• Common pump room alarm               <ul style="list-style-type: none"> <li>• Overvoltage</li> <li>• Undervoltage</li> <li>• Phase unbalance</li> </ul> </li> <li>• Common motor trouble               <ul style="list-style-type: none"> <li>• Overcurrent</li> <li>• Undercurrent</li> <li>• Fail to start</li> </ul> </li> </ul>		
<b>ViZiTouch Light Operator Interface</b>	<ul style="list-style-type: none"> <li>• Embedded microcomputer with software PLC logic</li> <li>• 4.2" color touch screen (HMI technology)</li> <li>• Upgradable software</li> <li>• Expandable storage</li> <li>• Multi-language</li> </ul>		
<b>Operation</b>	<b>Automatic Start</b>	<ul style="list-style-type: none"> <li>• Start on pressure drop</li> <li>• Remote start signal from automatic device</li> </ul>	
	<b>Manual Start</b>	<ul style="list-style-type: none"> <li>• Start pushbutton</li> <li>• Run test pushbutton</li> <li>• Deluge valve start</li> <li>• Remote start from manual device</li> </ul>	
	<b>Stopping</b>	<ul style="list-style-type: none"> <li>• Manual with Stop pushbutton</li> <li>• Automatic after expiration of minimum run timer **</li> </ul>	
	<b>Timers</b>	Field Adjustable & Visual Countdown	<ul style="list-style-type: none"> <li>• Minimum run timer **(off delay)</li> <li>• Sequential start timer (on delay)</li> <li>• Manual test timer</li> </ul>
	<b>Actuation</b>	Visual Indication	<ul style="list-style-type: none"> <li>• Pressure</li> <li>• Non-pressure</li> </ul>
	<b>Mode</b>		<ul style="list-style-type: none"> <li>• Automatic</li> <li>• Non-automatic</li> </ul>

\*\* Can only be used if approved by the AHJ



<input type="checkbox"/>	A4	Flow switch provision
<input type="checkbox"/>	A9	Low zone pump control function
<input type="checkbox"/>	A10	Middle zone pump control function
<input type="checkbox"/>	A11	High zone pump control function
<input type="checkbox"/>	A13	Non-pressure actuated controller w/o pressure transducer and run test solenoid valve
<input type="checkbox"/>	A16	Lockout/interlock circuit from equipment installed inside the pump room
<input type="checkbox"/>	B11B	Built in alarm panel same as B11 but 220-240VAC supervisory power
<input type="checkbox"/>	B19A	High motor temperature c/w thermostat relay and alarm contacts (DPDT)
<input type="checkbox"/>	B19B	High motor temperature c/w PT100 relay and alarm contacts (DPDT)
<input type="checkbox"/>	B21	Ground fault alarm detection c/w visual indication and alarm contact (DPDT)
<input type="checkbox"/>	C1	Extra motor run alarm contact (DPDT)
<input type="checkbox"/>	C4	Periodic test alarm contact (DPDT)
<input type="checkbox"/>	C6	Low discharge pressure alarm contact (DPDT)
<input type="checkbox"/>	C7	Low pump room temperature alarm contact (DPDT)
<input type="checkbox"/>	C10	Low water reservoir level alarm contact (DPDT)
<input type="checkbox"/>	C11	High electric motor temperature alarm contact (DPDT)
<input type="checkbox"/>	C12	High electric motor vibration c/w visual indication and alarm contact (DPDT)
<input type="checkbox"/>	C14	Pump on demand / automatic start alarm contact (DPDT)
<input type="checkbox"/>	C15	Pump fail to start alarm contact (DPDT)
<input type="checkbox"/>	C16	Control voltage healthy alarm contact (DPDT)
<input type="checkbox"/>	C17	Flow meter valve loop open c/w visual indication and alarm contact (DPDT)
<input type="checkbox"/>	C18	High water reservoir level c/w visual indication and alarm contact (DPDT)
<input type="checkbox"/>	C19	Emergency start alarm contact (DPDT)

<input type="checkbox"/>	C20	Manual start alarm contact (DPDT)
<input type="checkbox"/>	C21	Deluge valve start alarm contact (DPDT)
<input type="checkbox"/>	C22	Remote automatic start alarm contact (DPDT)
<input type="checkbox"/>	C23	Remote manual start alarm contact (DPDT)
<input type="checkbox"/>	C24	High pump room temperature alarm contact (DPDT)
<input type="checkbox"/>	Cx	Additional visual and alarm contact (Specify function) (DPDT)
<input type="checkbox"/>	D1	Low suction pressure transducer for fresh water rated at 0-300PSI with visual indication and alarm contact
<input type="checkbox"/>	D1A	Low suction pressure transducer for sea water rated at 0-300PSI with visual indication and alarm contact
<input type="checkbox"/>	D5E	Addition of run test solenoid valve for fresh water rated for 0-500psi
<input type="checkbox"/>	D5F	Addition of run test solenoid valve for sea water rated for 0-500psi
<input type="checkbox"/>	D14	Anti-condensation heater & thermostat
<input type="checkbox"/>	D14A	Anti-condensation heater & humidistat
<input type="checkbox"/>	D14B	Anti-condensation heater & thermostat & humidistat
<input type="checkbox"/>	D15	Tropicalization
<input type="checkbox"/>	D18	CE Mark with factory certificate
<input type="checkbox"/>	D27	Motor heater connection (external single phase power source and heater on/off contact)
<input type="checkbox"/>	D27A	Motor heater connection (internal single phase power source and heater on/off contact)
<input type="checkbox"/>	D28	Customized drawing set
<input type="checkbox"/>	D34A	Field programmable I/O board - 8 Input / 5 output
<input type="checkbox"/>	D37	Window kit for operator interface

Note: Options chosen from this page are not electrically represented on the wiring schematics in this submittal package.



<input type="checkbox"/>	L01	Other language and English (bilingual)
<input type="checkbox"/>	L02	French
<input type="checkbox"/>	L03	Spanish
<input type="checkbox"/>	L04	German
<input type="checkbox"/>	L05	Italian
<input type="checkbox"/>	L06	Polish
<input type="checkbox"/>	L07	Romanian
<input type="checkbox"/>	L08	Hungarian
<input type="checkbox"/>	L09	Slovak
<input type="checkbox"/>	L10	Croatian
<input type="checkbox"/>	L11	Czech
<input type="checkbox"/>	L12	Portuguese
<input type="checkbox"/>	L13	Dutch
<input type="checkbox"/>	L14	Russian
<input type="checkbox"/>	L15	Turkish
<input type="checkbox"/>	L16	Swedish
<input type="checkbox"/>	L17	Bulgarian
<input type="checkbox"/>	L18	Thai
<input type="checkbox"/>	L19	Indonesian
<input type="checkbox"/>	L20	Slovenian
<input type="checkbox"/>	L21	Danish
<input type="checkbox"/>	L22	Greek
<input type="checkbox"/>	L23	Arabic
<input type="checkbox"/>	L24	Hebrew
<input type="checkbox"/>	L25	Chinese

### ViZiTouch Light Operator Interface

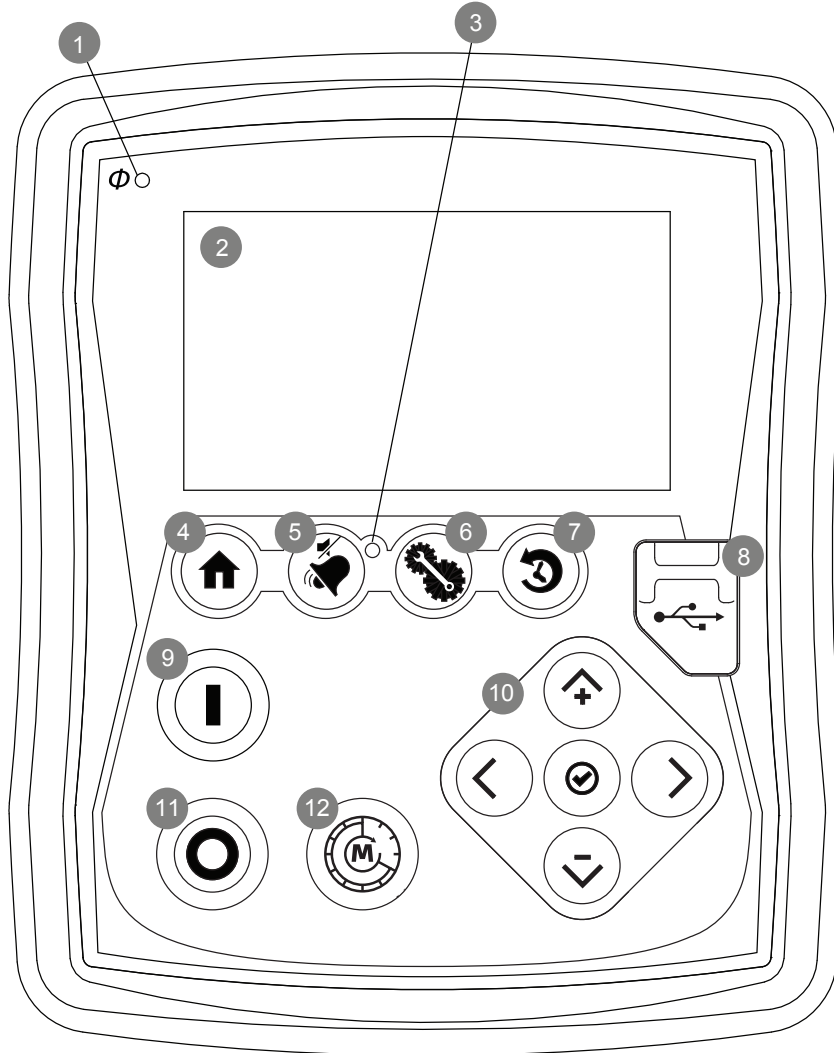

- |                               |                               |
|-------------------------------|-------------------------------|
| 1 - Power on LED              | 8 - USB port                  |
| 2 - Color touch screen        | 9 - START button              |
| 3 - Alarm LED                 | 10- Contextual navigation pad |
| 4 - HOME page button          | 11 - STOP button              |
| 5 - ALARM page button         | 12 - RUN TEST button          |
| 6 - CONFIGURATION page button |                               |
| 7 - HISTORY page button       |                               |

# Electric Fire Pump Controller

## Reduced Voltage / Wye Delta (Open Transition)

Dimension

### Model: GFY

Built as per NFPA 20-2013 standard



Optional

DESCRIPTION

DD/MM/YY

04/02/16



Drawing No.:

11/11/16

18/06/18

GFY-D1500 /E

GFX-S1-VIZI

REV.	DESCRIPTION	DD/MM/YY
0.	FIRST ISSUE	04/02/16
1.	TITLE BLOCK INFORMATION CHANGED	11/11/16
2.	REVISED LOGO	18/06/18

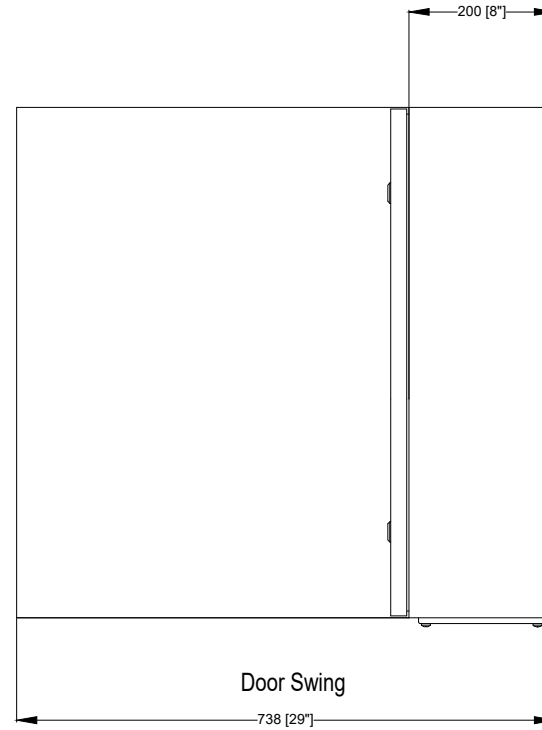
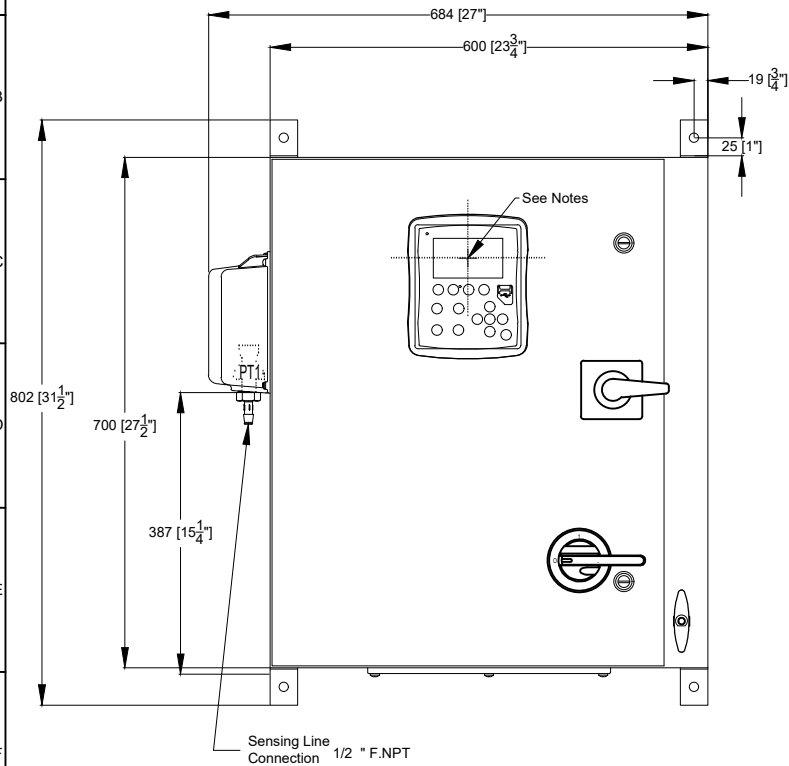

Power Table

Voltage	Min	Max
220 - 240	5 HP	40 HP
	4 kW	22 kW
380 - 400 - 415	5 HP	60 HP
	4 kW	45 kW

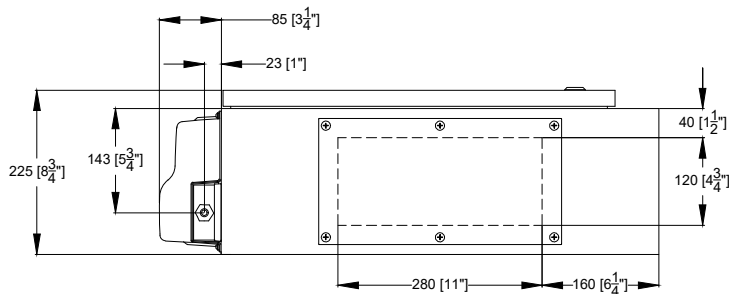

**Notes:**

- IP55 assembly.
- All dimensions are in millimeters [Inches].
- Center of ViZiTouch screen: 562 [22-1/4"] from bottom.
- Paint: textured red RAL 3002.
- Bottom conduit entrance through removable gland plate recommended.
- Use watertight conduit and connectors only.
- Protect equipment against drilling chips.
- Drawing for information only.

Manufacturer reserves the right to modify this drawing without notice.  
Contact manufacturer for "As Built" drawing.

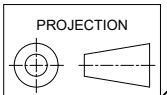

# Electric Fire Pump Controller

## Reduced Voltage / Wye Delta (Open Transition)

### Wiring schematic

### Model: GFY

Built as per NFPA 20-2013 standard

Optional		CE	
REV.	DESCRIPTION	DD/MM/YY	TORNATECH
0.	FIRST ISSUE	01/02/16	Drawing No.
1.	TITLE BLOCK INFORMATION CHANGED	11/11/16	GFY-WS500 /E
2.	REVISED LOGO	18/06/18	GFX-S1-VIZI

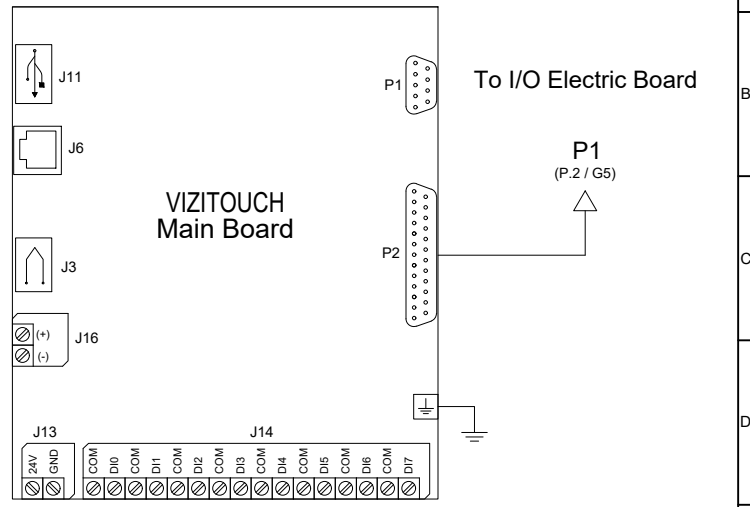
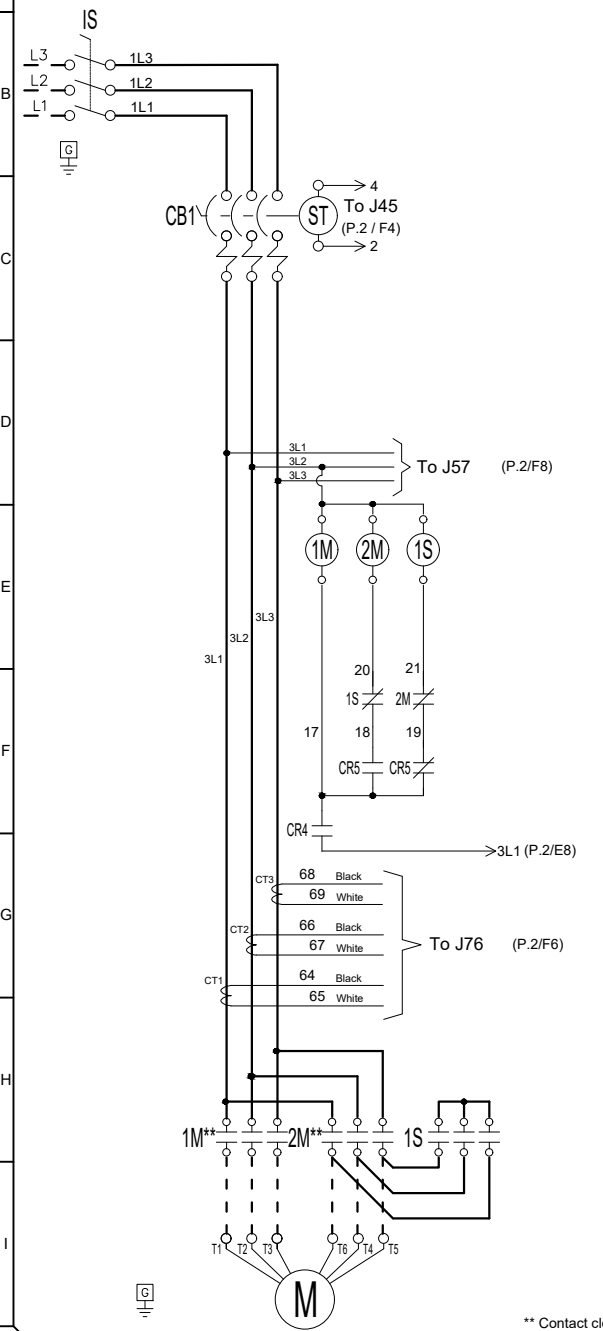

\*\* Contact closes when emergency starts is in "ON" position.

**Note:**  
 - Drawing for information only.  
 Manufacturer reserves the right to modify this drawing without notice.  
 Contact manufacturer for "As Built" drawing.



# Electric Fire Pump Controller

## Reduced Voltage / Wye Delta (Open Transition)

### Wiring schematic

Model: GFY

Built as per NFPA 20-2013 standard



Optional

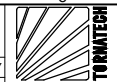

REV.	DESCRIPTION	DD/MM/YY
0.	FIRST ISSUE	01/02/16
1.	TITLE BLOCK INFORMATION CHANGED	11/11/16
2.	REVISED LOGO	18/06/18

Drawing No. GFY-WS500 /E

GFX-S1-VIZI

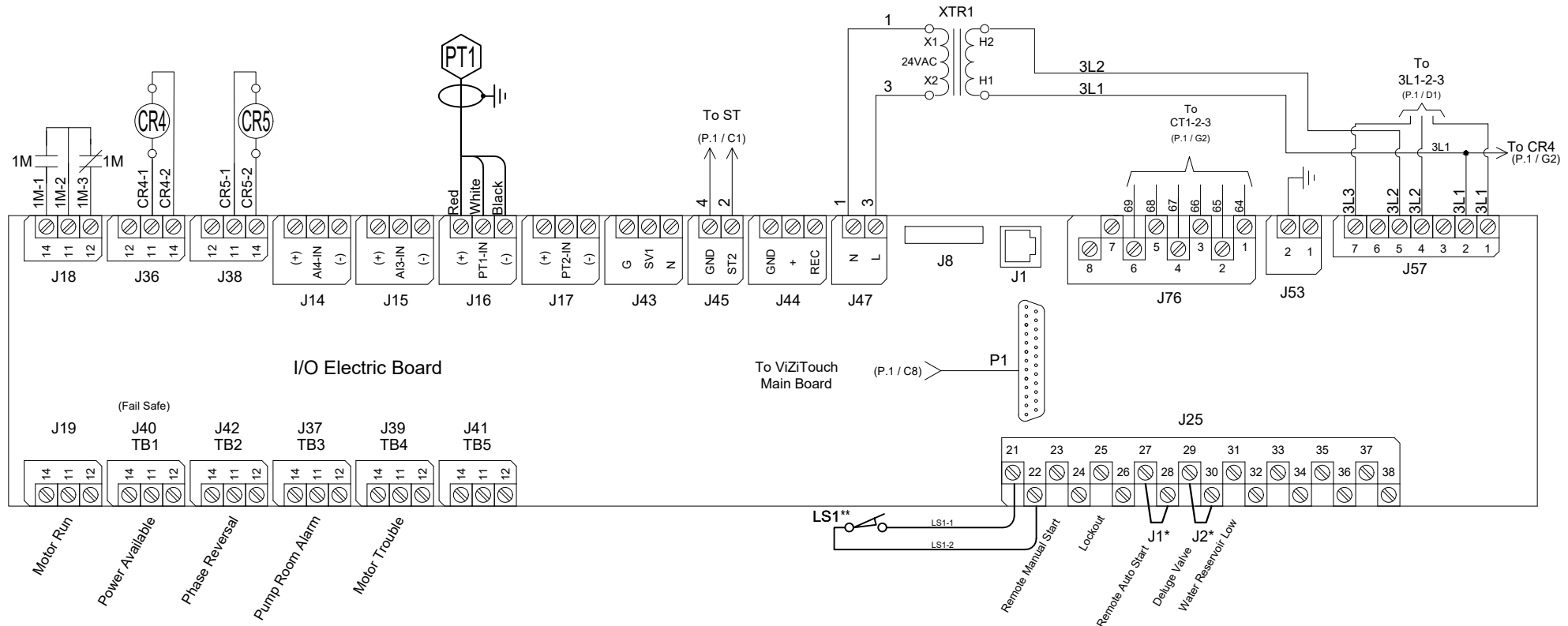

\* Remove this jumper to use this feature  
 \*\* Contact closes when emergency start is in "ON" position.

# Electric Fire Pump Controller

## Reduced Voltage / Wye Delta (Open Transition)

### Model: GFY

Built as per NFPA 20-2013 standard



REV.	DESCRIPTION	DD/MM/YY	Drawing No.
0.	FIRST ISSUE	01/02/16	
1.	TITLE BLOCK INFORMATION CHANGED	11/11/16	
2.	REVISED LOGO	18/06/18	

GFY-WS500 /E

GFX-S1-VIZI

### Terminals diagram

### Field Connections

#### Normal Power Connections

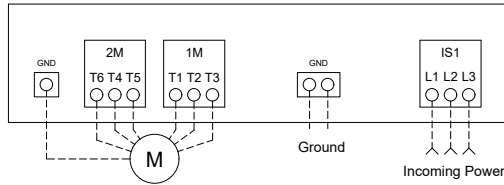

### Field Connections

Terminals Wire Size:  
12 - 24 AWG  
0.5 Nm

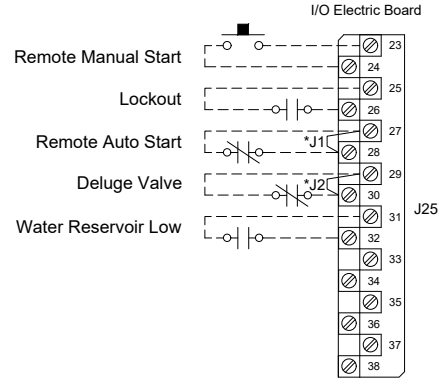

Control Terminal Strip

### Alarm Contacts

Terminals Wire Size:  
12 - 24 AWG  
0.5 Nm

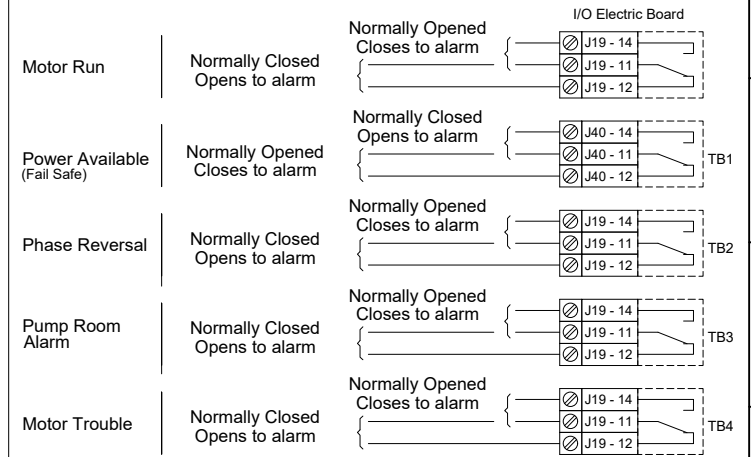

\* Remove this jumper to use this feature