



TORNATECH

Project: _____

Customer: _____

Engineer: _____

Pump Manufacturer: _____

Technical Data
Submittal Document

Model HFD

Diesel Fire Pump Controller
Built to EN17451

Contents:

Data Sheets
Dimensional Data
Wiring Schematics
Field Connections

Note: The drawings included in this package are for controllers covered under our standard offering. Actual AS BUILT drawings may differ from what is shown in this package.



April 2026



Standard & Certification	Built to EN17451	
	CE Mark: Various EN, IEC & CEE directives and standards	
Enclosure	Protection Rating Standard: IP55	
	Accessories • Bottom entry gland plate • Special tool ¼ turn locks	Paint Specifications • Red RAL3002 • Powder coating • Glossy textured finish
General	AC	208V to 240V/1ph/50-60hz
	DC	12VDC 24VDC
	Grounding system	• Negative
	Battery chargers	• Two independent fully automatic • 10A continuous charge • 500mA trickle charge
Disconnecting Means	<ul style="list-style-type: none"> Isolating switch: <ul style="list-style-type: none"> Door interlocked in the ON position 	
Electrical Reading	<ul style="list-style-type: none"> Battery 1 & Battery 2 voltage Battery 1 & Battery 2 charging amperage 	
Pressure and Event Recorder	<ul style="list-style-type: none"> Pressure readings with date stamp Event recording with date stamp Under regular maintained operation, events are stored in memory for the life of the controller. Data viewable on operator interface display screen Downloadable by USB port to external memory device or to App (smartphone application) 	
Terminal to Connect Starting Devices	<ul style="list-style-type: none"> Provision to connect two (2) externally mounted pressure switches (by others) <ul style="list-style-type: none"> Internally connected in parallel with normally open contacts when start pressure us above the desired start pressure Contacts close when pressure loss occurs 	
Terminals to Connect Engine Monitoring Devices	<ul style="list-style-type: none"> Engine speed sensor Engine temperature sensor Engine oil pressure sensor 	
Terminals to Connect Field Devices	<ul style="list-style-type: none"> Low Fuel Level switch Fuel valve closed Remote auto start Discharge pressure switch 	
Engine Monitoring Gauges	Digitally represented on ViZiTouch operator interface: <ul style="list-style-type: none"> Oil pressure Temperature RPM 	
Audible Alarm	Alarm buzzer - 85dB at 3 meters	
Visual Indications	<ul style="list-style-type: none"> Battery and charger 1 & 2 voltage and amperage Crank cycle Engine running/stopped Engine RPM Engine temperature 	<ul style="list-style-type: none"> Engine oil pressure Time and date Pump room temperature (°F or °C) Time and date



Visual & Audible Alarms	Visual only		
	<ul style="list-style-type: none"> • Charger Failure 1-2 		
Visual & Audible Alarms	Visual and Audible		
	<ul style="list-style-type: none"> • DC Failure • Battery 1 Failure • Battery 2 Failure • Loss of Continuity 1 • Loss of Continuity 2 • Engine Fail to Start • Engine Overspeed • Pump on Demand 	<ul style="list-style-type: none"> • Not In Auto • Low Fuel Level • ECM SS in Alt. Pos • Fuel Injection Malfunction • Engine High Temperature • Engine Low Coolant Temperature 	<ul style="list-style-type: none"> • Electronic Control Module Fault • Engine Low Oil Pressure • High Raw Water Temperature • PLD Low Suction Pressure • Pump Failed to Start • Operate manual test start
Remote Alarm Contacts	<ul style="list-style-type: none"> • General Fault (fail safe) • Pump Running • Auto Mode Bypass (fail safe) • Fail to Start • Pump on Demand 		
ViZiTouch V2.1 Operator Interface	<ul style="list-style-type: none"> • Embedded microcomputer with software PLC logic • 7.0" color touch screen (HMI technology) • Upgradable software • Multi-language 		
Operation	Automatic Start	<ul style="list-style-type: none"> • Start on pressure drop (pressure switch by others) 	
	Manual Start	<ul style="list-style-type: none"> • Crank start pushbutton • Run test pushbutton 	
	Crank Cycle	<ul style="list-style-type: none"> • 6 consecutive cycle attempts <ul style="list-style-type: none"> • 10s crank from battery 1 or 2 alternatively • 10s rest in between each crank attempt 	
	Stopping	<ul style="list-style-type: none"> • Manual with Stop pushbutton 	
	Timers	Field Adjustable & Visual Countdown	<ul style="list-style-type: none"> • Sequential start timer (on delay)
	Actuation	Visual Indication	<ul style="list-style-type: none"> • Pressure • Non-Pressure
	Mode		<ul style="list-style-type: none"> • Automatic • Auto-mode bypass (Used for maintenance and to prevent the automatic start)



AX45	Engine coolant NO FLOW alarm
B1	Low fuel level alarm contact (Form C-SPDT)
C7	Engine block heater circuit 3 Kw max
C13	Louver activation circuit (battery power specific)
C13A	Louver activation circuit when engine is not running 24VDC controller with 24VDC louver motor
C13F	Louver activation circuit when engine is not running 24VDC controller with 12VDC louver motor
D7B	Low fuel level float 1-1/2" (supplied as separate item)
D9A	Anti-condensation heater & thermostat
D9B	Anti-condensation heater & humidistat
I02	Gauge indication for fuel level
I03	MANU-OFF-AUTO 3 pos key selector switch
I10	Emergency manual start according to EN12845 void EN17451

L01	Other language and English (bilingual)
L02	French
L03	Spanish
L04	German
L05	Italian
L06	Polish
L07	Romanian
L08	Hungarian
L09	Slovakian
L10	Croatian
L11	Czech
L12	Portuguese
L13	Dutch
L15	Turkish
L16	Swedish
L21	Danish
L25	Chinese
L28	Finnish
L29	Norwegian

Note: Options chosen from this page are not electrically represented on the wiring schematics in this submittal package.

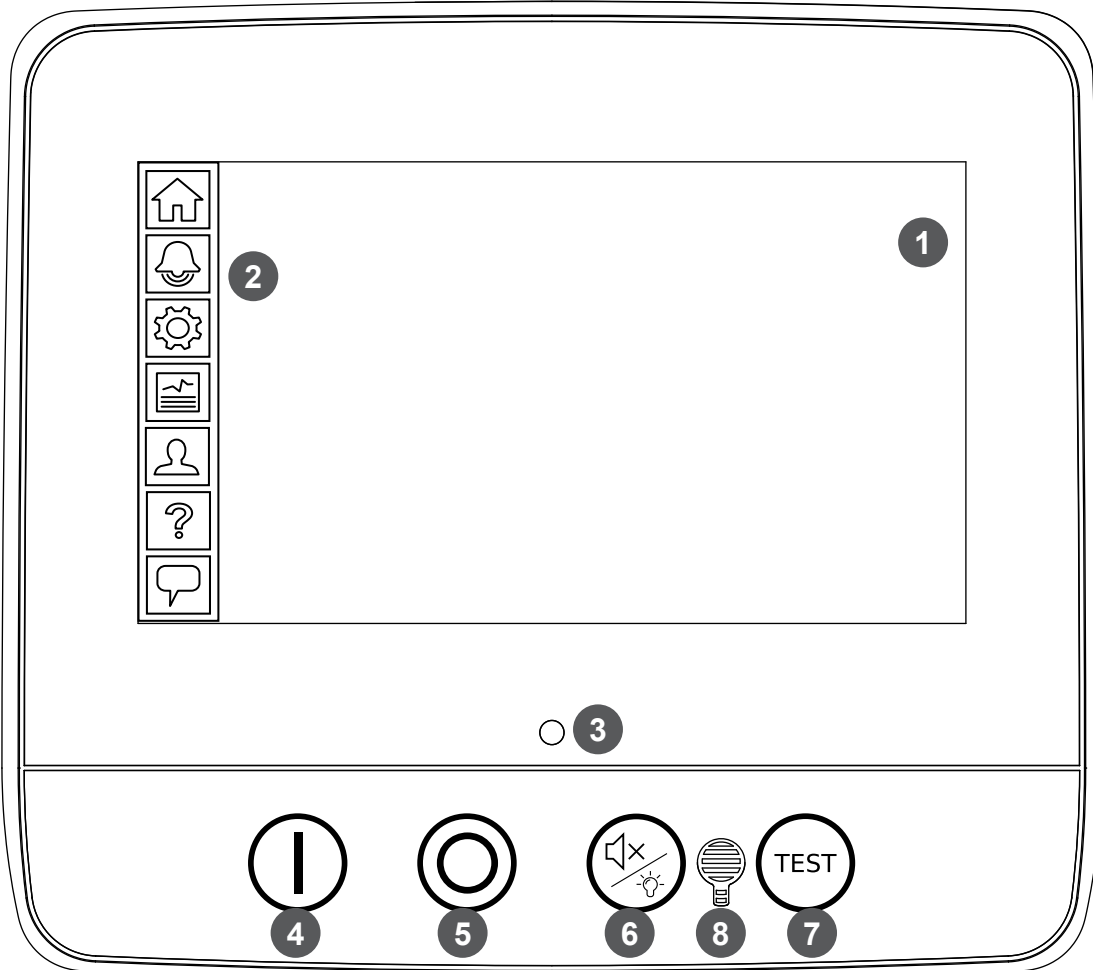
ViZiTouch V2.1 Operator Interface

- | | |
|------------------------|--------------------------------|
| 1 - Color touch screen | 3 - Power LED (3 colors) |
| 2 - Onscreen menu | 4 - START button |
| • HOME page | 5 - STOP button |
| • ALARM page | 6 - SILENCE / LAMP test button |
| • CONFIGURATION page | 7 - Run TEST button |
| • HISTORY page | 8 - Alarm buzzer |
| • SERVICE page | |
| • MANUAL page | |
| • LANGUAGES page | |



© Tornatech, Inc. Not for construction.
Subject to change without notice.

	BY	DD/MM/YY
DRAWN BY	ACD	01/11/23
FINAL APPROVAL	FC	01/11/23

DIESEL ENGINE FIRE PUMP CONTROLLER 12VDC OR 24VDC NEGATIVE GROUND

MODEL: HFD

BUILT TO THE LATEST EDITION OF THE EN 17451 STANDARD



THIRD ANGLE
PROJECTION

DRAWING NUMBER	HFD-DK620/E
DWG REV. 0	
SHEET 1 OF 1	

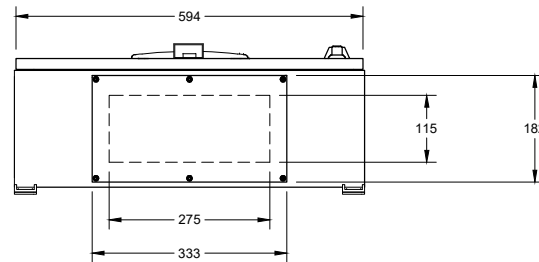
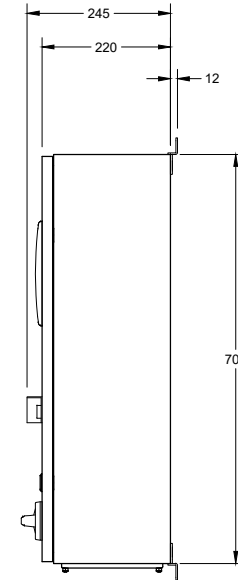
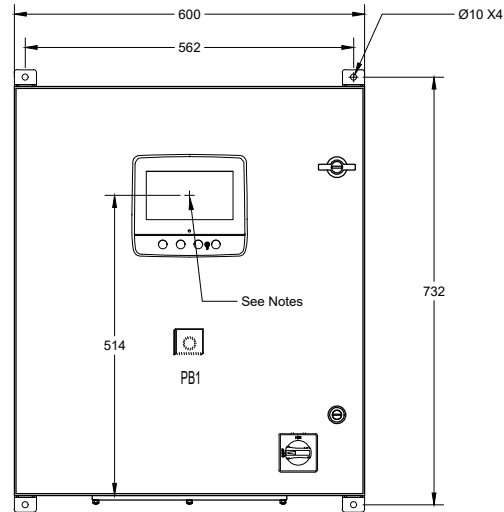
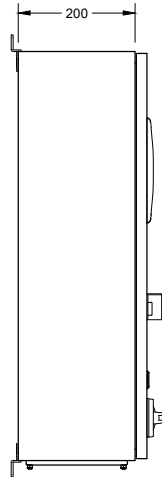

Notes:

- Standard: IP55
- Standard paint : textured red RAL 3002.
- All dimensions are in millimeters.
- Center of ViZITouch screen: 514 mm from bottom (no feet).
- Bottom conduit entrance through removable gland plate recommended.
- Use watertight conduit and connector only.
- Protect equipment against drilling chips.
- Door swing equal to door width.



© Tornatech, Inc. Not for construction.
Subject to change without notice.

BY	DD/MM/YY
DRAWN BY	DDS 20/03/26
FINAL APPROVAL	GC 20/03/26

DIESEL ENGINE FIRE PUMP CONTROLLER 12VDC OR 24VDC NEGATIVE GROUND

MODEL: HFD

BUILT TO THE LATEST EDITION OF THE EN 17451 STANDARD



DRAWING NUMBER	HFD-WS620/E
DWG REV. 1	
SHEET 1 OF 2	

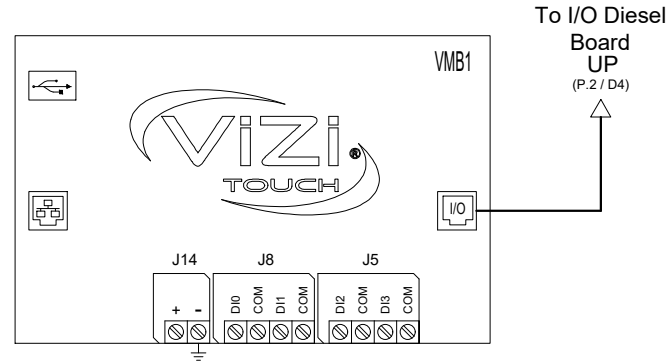
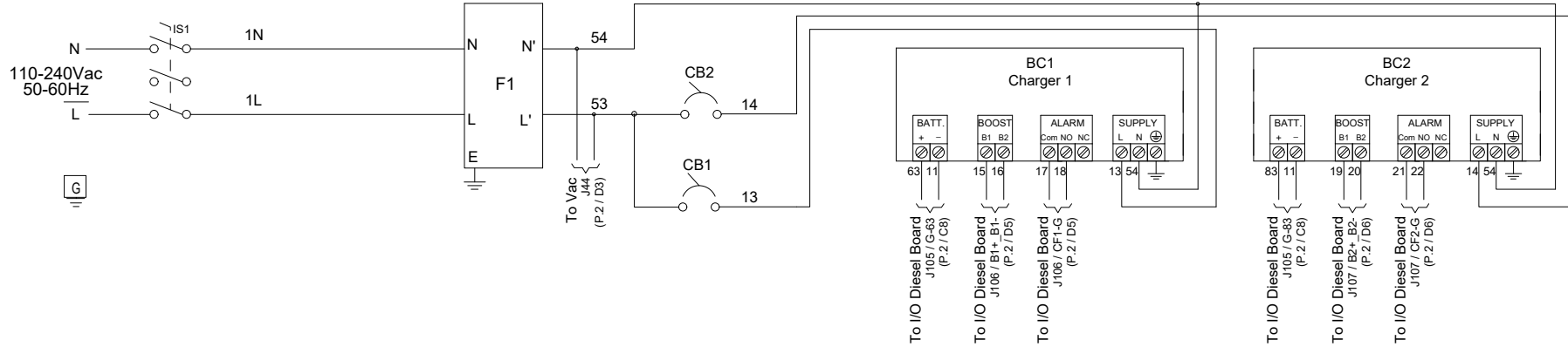

Legend	
BC	Battery Charger
CB	Circuit Breaker
DB	Diesel I/O Board
F	Filter
IS	Isolating Switch
J	Jumper
PB	Start Push Button
VMB	Main Board



© Tornatech, Inc. Not for construction.
Subject to change without notice.

BY	DD/MM/YY
DRAWN BY	DDS 20/03/26
FINAL APPROVAL	GC 20/03/26

DIESEL ENGINE FIRE PUMP CONTROLLER 12VDC OR 24VDC NEGATIVE GROUND

MODEL: HFD

BUILT TO THE LATEST EDITION OF THE EN 17451 STANDARD



DRAWING NUMBER	HFD-WS620/E
DWG REV.	1
SHEET 2 OF 2	

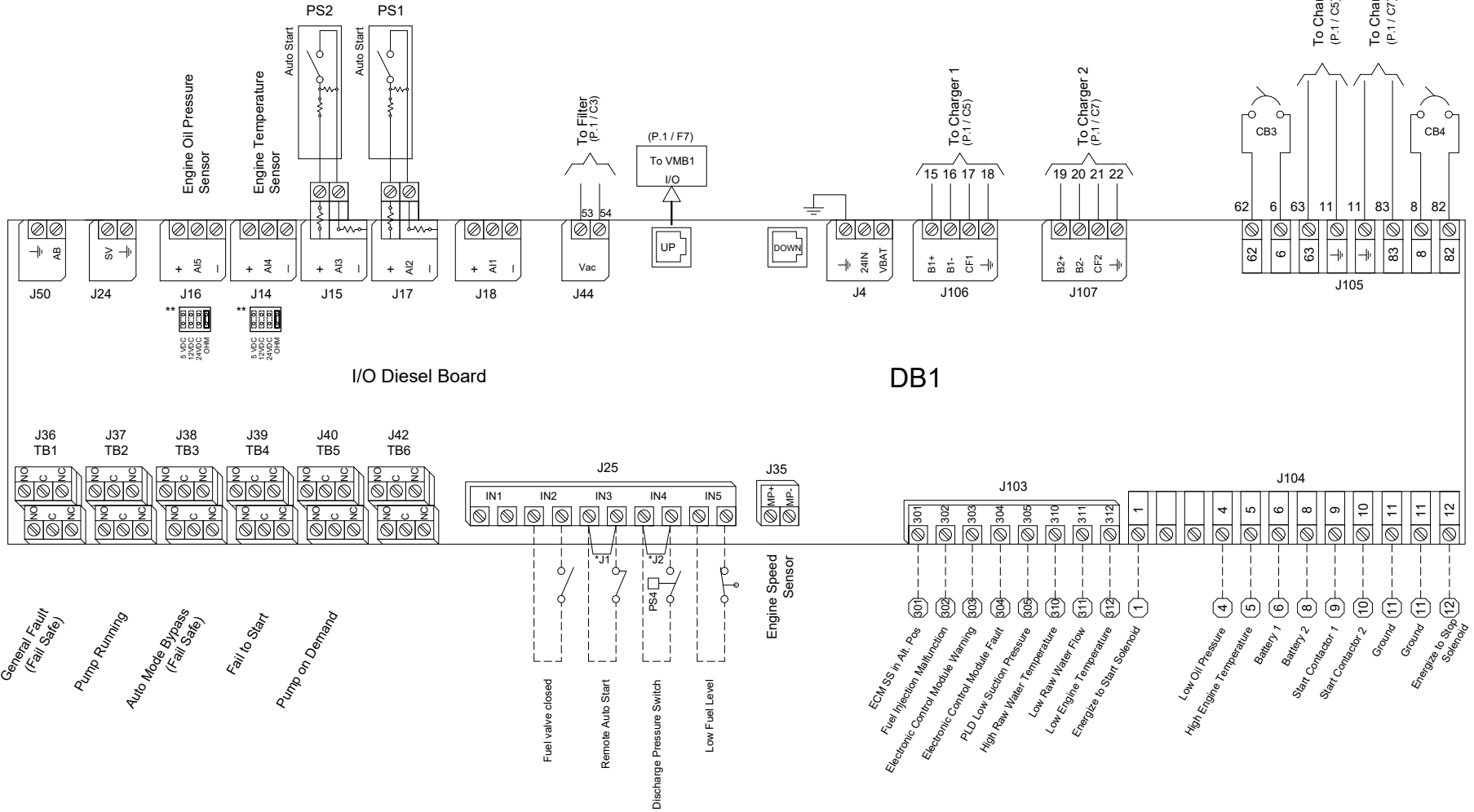

* Remove this jumper to use this feature
** All other jumpers are placed in 5Vdc



© Tornatech, Inc. Not for construction.
Subject to change without notice.

	BY	DD/MM/YY
DRAWN BY	ACD	01/11/23
FINAL APPROVAL	FC	01/11/23

DIESEL ENGINE FIRE PUMP CONTROLLER 12VDC OR 24VDC NEGATIVE GROUND

MODEL: HFD

BUILT TO THE LATEST EDITION OF THE EN 17451 STANDARD



DRAWING NUMBER	HFD-LY620/E
DWG REV. 0	
SHEET 1 OF 1	

Designation	Description
BC1-BC2	Battery Charger #1 and #2
CB1-2	Magnetic Breaker 1 Pole 10 A
CB3-4	Magnetic Breaker 1 Pole 16 A
DB1	I/O Diesel Board
F1	Filter
IS1	Isolating Switch
PB1	Emergency start Push Button
VMB1	Main Board

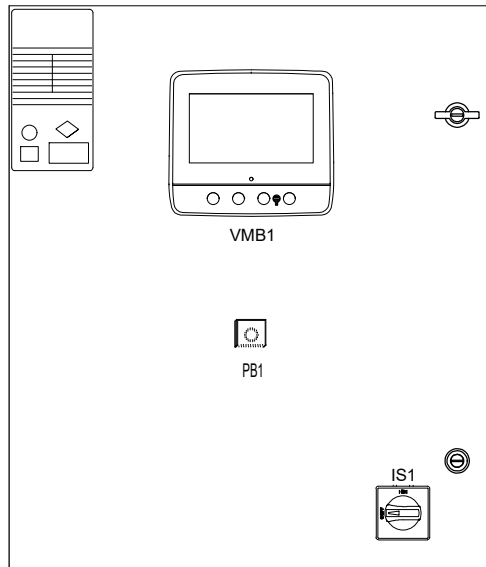

Front Door Layout

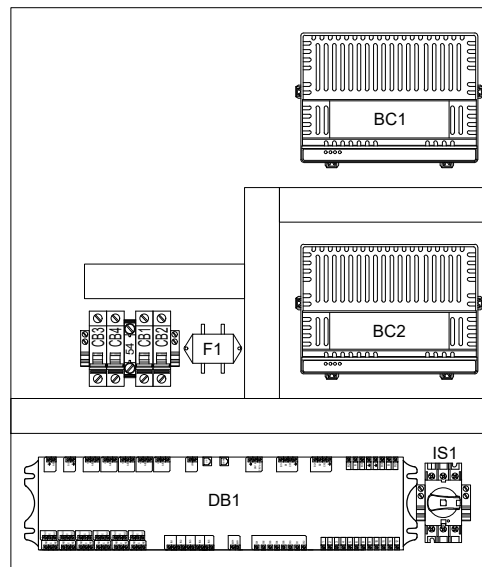

Internal Layout



© Tornatech, Inc. Not for construction. Subject to change without notice.

BY	DDS	DD/MM/YY
DRAWN BY	DDS	20/03/26
FINAL APPROVAL	GC	20/03/26

DIESEL ENGINE FIRE PUMP CONTROLLER 12VDC OR 24VDC NEGATIVE GROUND

MODEL: HFD

BUILT TO THE LATEST EDITION OF THE EN 17451 STANDARD



DRAWING NUMBER	HFD-TD620/E
DWG REV. 1	
SHEET 1 OF 1	

Power Supply

Terminals Wire Size:
1.5 - 16 mm²
1.9 Nm

110-240Vac
50-60Hz

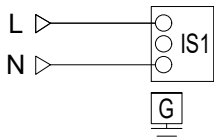

Engine Connections

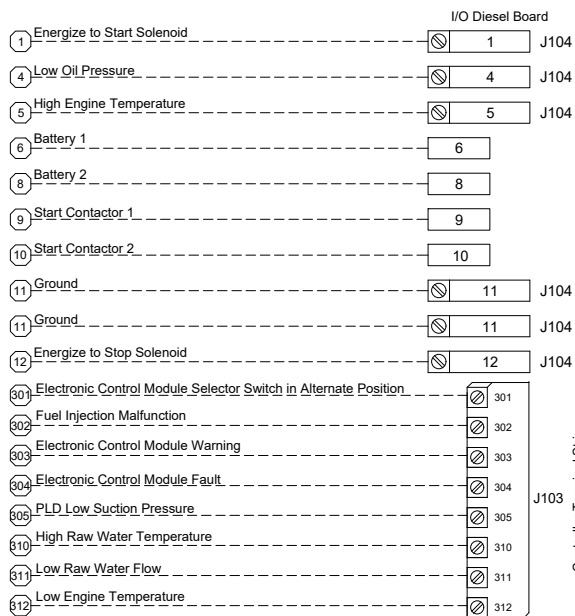

Field Connections

Terminals Wire Size:
0.5 - 4 mm²
0.5 Nm

- Fuel valve closed
- Remote Auto Start
- Discharge Pressure Switch
- Low Fuel Level

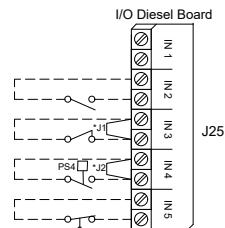

Network Connections

Terminals Wire Size:
Shielded Female Connector RJ45

Modbus TCP/IP

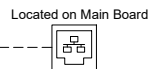

Engine Connections

0.5 - 4 mm²
0.5 Nm

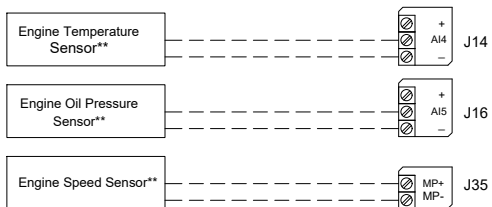

Field Connections

Terminals Wire Size:
0.5 - 4 mm²
0.5 Nm

Pressure Switch 1**

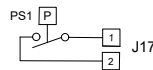

Pressure Switch 2**

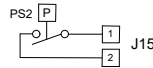

Alarm Contacts

Terminals Wire Size:
0.5 - 2.5 mm²
0.5 Nm

General Fault (Fail Safe)

Pump Running

Auto Mode Bypass (Fail Safe)

Fail to Start

Pump on Demand

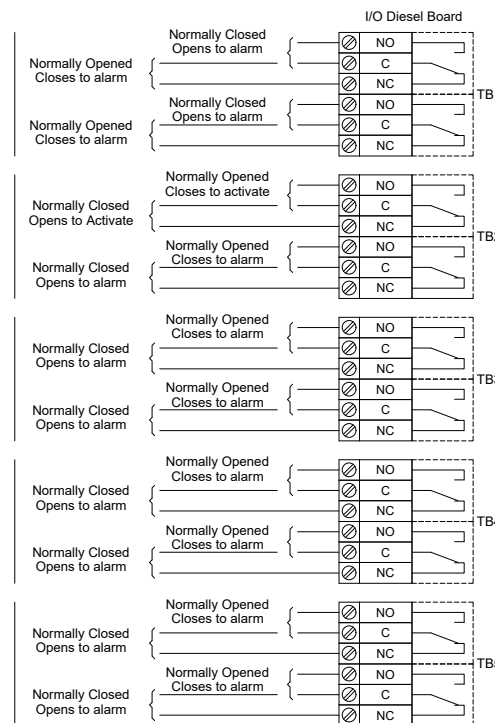

* Remove this jumper to use this feature
** Shielded cable required. Shield must be grounded on the opposite side of the controller.