

Dimensions

Built to the latest edition of the EN 12845 standard

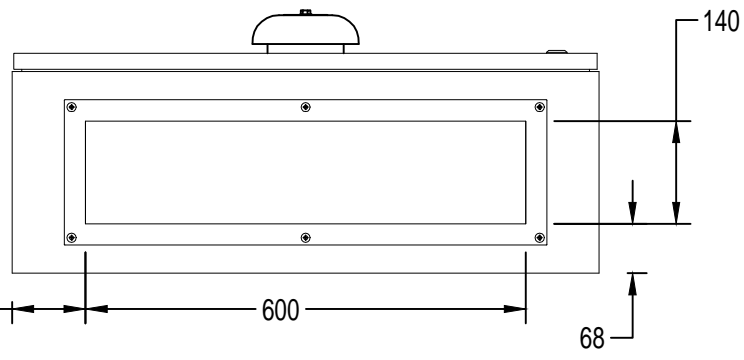
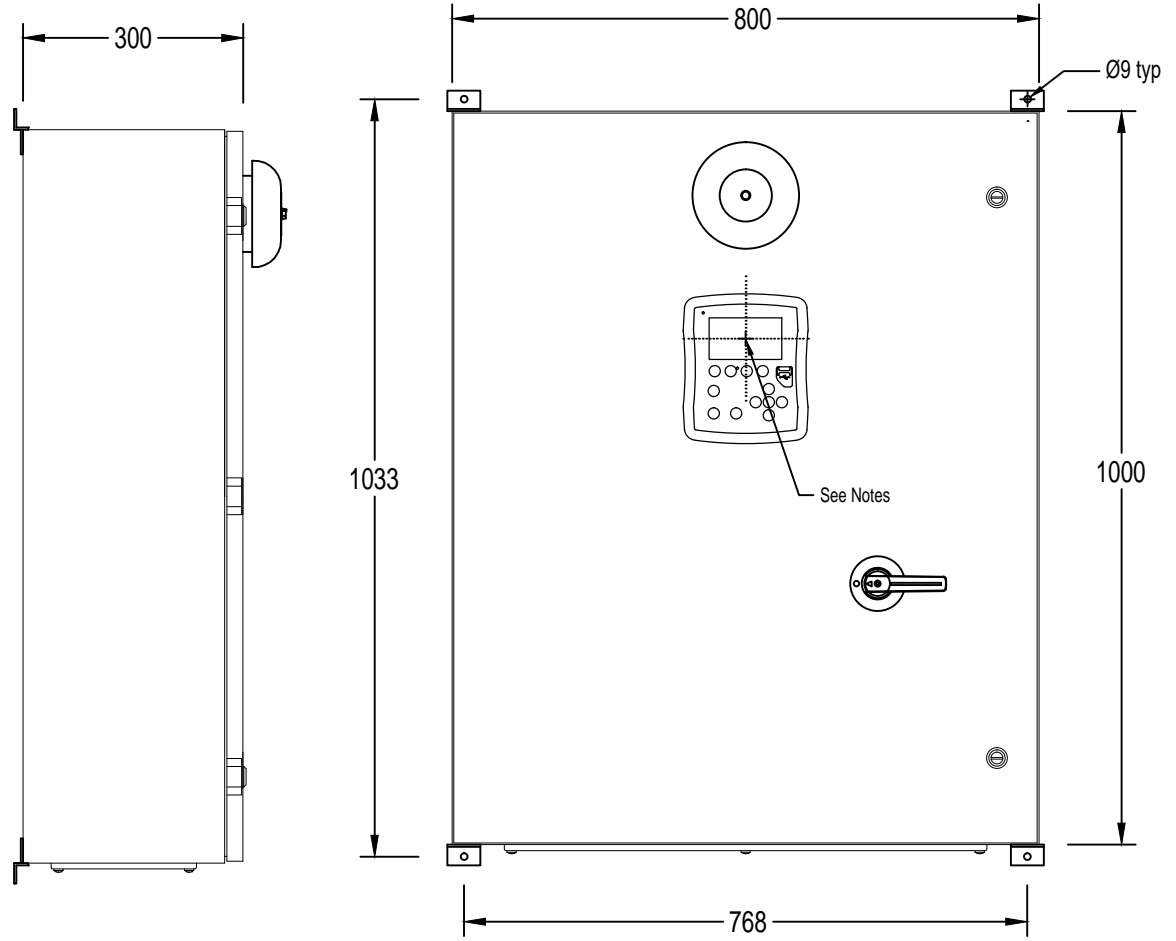

Voltage / Power Table		
Voltage	Min	Max
380 - 400 - 415	45 kW	250 kW

Notes:

- Standard: IP55
- Standard Paint : Textured Red RAL 3002.
- All Dimensions are in Millimeters.
- Center of ViZiTouch Screen: 690mm from Bottom.
- Bottom Conduit Entrance Through Removable Gland Plate Recommended.
- Use Watertight Conduit and Connector Only.
- Protect Equipment Against Drilling Chips.
- Door Swing Equal to Door Width.

Drawing for information only.
 Manufacturer reserves the right to modify this drawing without notice.
 Contact manufacturer for "As Built" drawing.

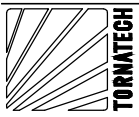
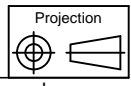

REV.	DESCRIPTION	DD/MM/YY	Drawing number
1	Modified the Enclosure	04/08/16	HFX-DI501 /E
2	General revision	23/08/17	
3	Revised logo	18/06/18	