



# TORNATECH

Project: \_\_\_\_\_

Customer: \_\_\_\_\_

Engineer: \_\_\_\_\_

Pump Manufacturer: \_\_\_\_\_

## Technical Data Submittal Document

# VPx Series

Full Service - Variable Speed  
Electric Fire Pump Controller  
with Automatic Power Transfer Switch

### Contents:

Data Sheets  
Dimensional Data  
Wiring Schematics  
Field Connections

Note: The drawings included in this package are for controllers covered under our standard offering. Actual AS BUILT drawings may differ from what is shown in this package.



June 2026



#### Select Bypass starting method

#### Model VPA+VPU Across the line

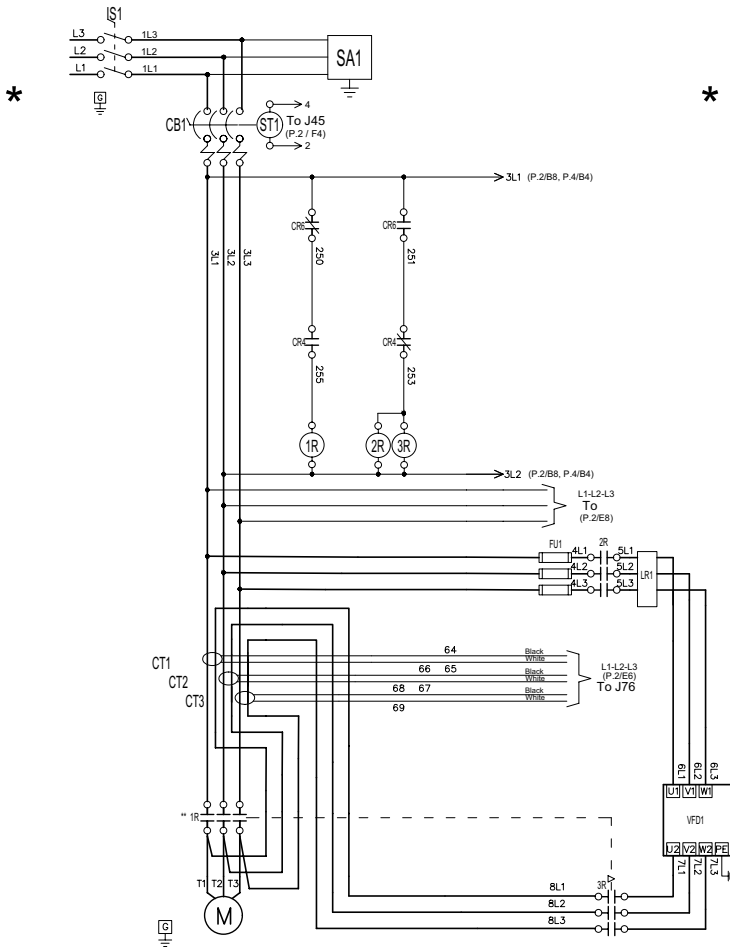

#### Model VPS+VPU Soft Start Soft Stop

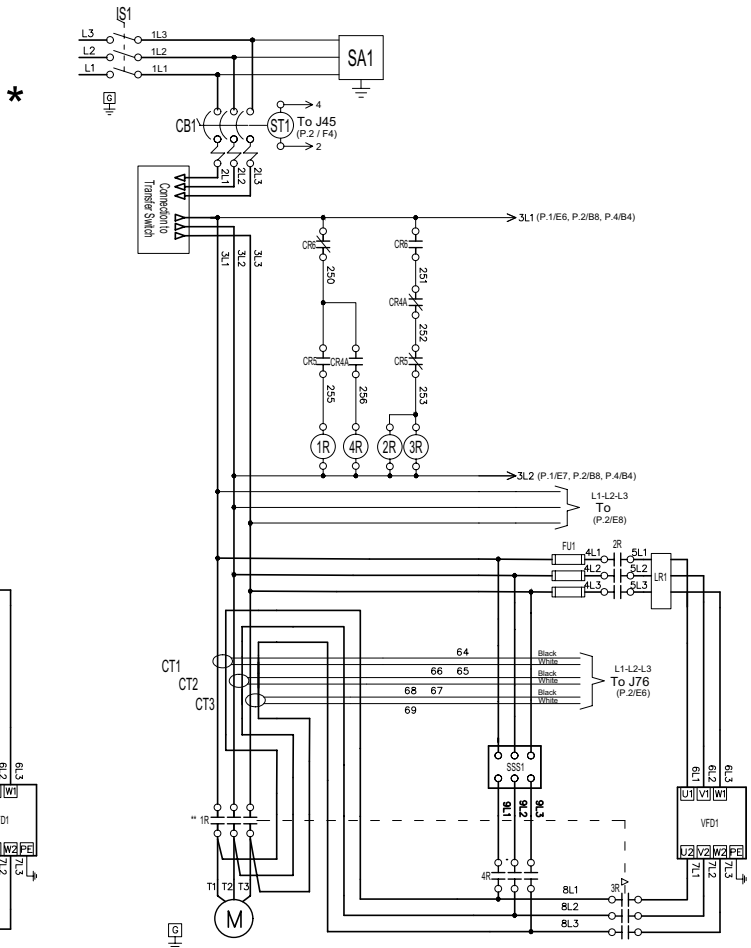

\*From normal incoming power through Disconnecting Means (IS/CB)

\*For Disconnecting Means details see page 3



**Select voltage and power rating**

<b>Voltage</b>	<b>Select Voltage</b>	<b>HP</b>	<b>Select HP</b>
200V/3ph/50-60Hz <sup>1</sup>		5	
208V/3ph/50-60Hz <sup>1</sup>		7.5	
220V/3ph/50-60Hz <sup>2</sup>		10	
230V/3ph/50-60Hz <sup>2</sup>		15	
240V/3ph/50-60Hz <sup>2</sup>		20	
380V/3ph/50-60Hz <sup>3</sup>		25	
400V/3ph/50-60Hz <sup>3</sup>		30	
415V/3ph/50-60Hz <sup>3</sup>		40	
440V/3ph/50-60Hz <sup>4</sup>		50	
460V/3ph/50-60Hz <sup>4</sup>		60	
480V/3ph/50-60Hz <sup>4</sup>		75	
575V/3ph/60Hz <sup>2</sup>		100	
600V/3ph/60Hz <sup>2</sup>		125	
		150	
		200	
		250	
		300	
		350	
		400	
		450	

- Notes: <sup>1</sup> Maximum power rating is 75HP.  
<sup>2</sup> Maximum power rating is 100HP.  
<sup>3</sup> Maximum power rating is 350HP.  
<sup>4</sup> Maximum power rating is 450HP.



<b>Standard, Listings, Approvals and Certifications</b>	<b>Built to NFPA 20</b>				
	<b>Underwriters Laboratory (UL)</b>	• UL218 - Fire Pump Controllers			
	<b>FM Global</b>	Class 1321/1323			
<b>Enclosure</b>	<b>Protection Rating</b>				
	Standard: NEMA 12 ventilated assembly				
	<b>Accessories</b> • Gland plate(s) • Lifting Lugs • Keylock handle		<b>Paint Specifications</b> • Red RAL3002 • Powder coating • Glossy textured finish		
<b>Shortcircuit Withstand Rating</b>	<b>200V 60Hz</b>	<b>208V to 240V 60Hz</b>	<b>380V to 415V 50 Hz / 60Hz</b>	<b>440V to 480V 60Hz</b>	<b>575V to 600V 60Hz</b>
	<b>HP (kw)</b>				
	5 to 75	5 to 100	5 to 350	5 to 450	5 to 100
	Standard 100kA				Standard 50kA
<b>Ambient Temperature Rating</b>	<b>Standard:</b> 4°C to 40°C / 39°F to 104°F				
<b>Surge Suppression</b>	Surge arrestor rated to suppress surges above line voltage				
<b>Disconnecting Means</b>	<ul style="list-style-type: none"> <li>• Isolating switch and circuit breaker assembly:               <ul style="list-style-type: none"> <li>- Door interlocked in the ON position</li> <li>- Isolating switch rated not less than 115% of motor full load current</li> <li>- Circuit breaker continuous rating not less than 115% of motor full load current</li> <li>- Overcurrent sensing non-thermal type, magnetic only</li> <li>- Instantaneous trip setting of not more than 20 times the motor full load current</li> </ul> </li> <li>• Common flange mounted operating handle</li> <li>• Suitable as service entrance equipment (not applicable for installations in Canada).</li> </ul>				
<b>Service Entrance Rating</b>	Suitable as service entrance equipment				
<b>Emergency Start Handle</b>	• Flange mounted • Pull and latch activation		• Integrated limit switch • Across the line start (direct on line)		
<b>Locked Rotor Protector</b>	• Operate shunt trip to open circuit breaker • Factory set at 600% of motor full load current		• Trip between 8 and 20 seconds		
<b>Electrical Readings</b>	<ul style="list-style-type: none"> <li>• Voltage phase to phase (normal power)</li> <li>• Amperage of each phase when motor is running</li> </ul>				
<b>Pressure Readings</b>	<ul style="list-style-type: none"> <li>• Continuous system pressure display</li> <li>• Constant pressure output set-point</li> <li>• Cut-in and Cut-out pressure settings</li> </ul>				



<p><b>Pressure and Event recorder</b></p>	<ul style="list-style-type: none"> <li>• Pressure readings with date stamp</li> <li>• Event recording with date stamp</li> <li>• Under regular maintained operation, events are stored in memory for the life of the controller.</li> <li>• Data viewable on operator interface display screen</li> <li>• Downloadable by USB port to external memory device or wireless connection to manufacturers App (mobile device).</li> </ul>
<p><b>Pressure Sensing</b></p>	<ul style="list-style-type: none"> <li>• Pressure transducers and run test solenoid valve assembly for fresh water application</li> <li>• Pressure sensing line connection 1/2" Female NPT</li> <li>• Drain connection 3/8"</li> <li>• Rated for 0-500PSI working pressure (standard display at 0-300PSI)</li> <li>• Externally mounted with protective cover</li> </ul>
<p><b>Variable Speed Drive Circuit</b></p>	<ul style="list-style-type: none"> <li>• Variable speed drive (VFD)</li> <li>• Line reactor 5%</li> <li>• Mode selector switch             <ul style="list-style-type: none"> <li>• VFD</li> <li>• Bypass</li> </ul> </li> </ul>
<p><b>Audible Alarm</b></p>	<p>Alarm buzzer - 85dB at 3 meters</p>
<p><b>Visual Indications</b></p>	<ul style="list-style-type: none"> <li>• Power available</li> <li>• Motor run</li> <li>• Periodic test</li> <li>• Manual start</li> <li>• Deluge valve start</li> <li>• Remote automatic start</li> <li>• Remote manual start</li> <li>• Emergency start</li> <li>• Pump on demand/Automatic start</li> <li>• Pump room temperature (°F or °C)</li> <li>• Lockout</li> <li>• VFD fault</li> <li>• VFD bypass</li> <li>• VFD Hertz</li> </ul>
<p><b>Visual &amp; Audible Alarms</b></p>	<p>Visual</p> <ul style="list-style-type: none"> <li>• Control voltage not healthy</li> <li>• Invalid cut-in</li> <li>• Lock rotor current</li> <li>• Loss of power</li> <li>• Low ambient temperature</li> <li>• Low water level</li> <li>• Motor trouble</li> <li>• Phase reversal (normal power)</li> <li>• Overcurrent</li> <li>• Overvoltage</li> <li>• Phase loss L1</li> <li>• Phase loss L2</li> <li>• Phase loss L3</li> <li>• Phase unbalanced</li> <li>• Pressure transducer fault detected</li> <li>• Pump on demand</li> <li>• Pump room alarm</li> <li>• Service required</li> <li>• Undercurrent</li> <li>• Undervoltage</li> <li>• Check weekly test solenoid</li> <li>• Weekly test cut-in reached</li> </ul> <p>Visual and audible</p> <ul style="list-style-type: none"> <li>• Fail to start</li> </ul>
<p><b>Remote Alarm Contacts</b></p>	<p>DPDT-8A-250V.AC</p> <ul style="list-style-type: none"> <li>• Power available</li> <li>• Phase reversal</li> <li>• Motor run</li> <li>• Common pump room alarm (field re-assignable)**             <ul style="list-style-type: none"> <li>• Overvoltage</li> <li>• Undervoltage</li> <li>• Phase unbalance</li> <li>• Low pump room temperature</li> <li>• High Pump room temperature</li> </ul> </li> <li>• Common motor trouble (field re-assignable)**             <ul style="list-style-type: none"> <li>• Overcurrent</li> <li>• Fail to start</li> <li>• Undercurrent</li> <li>• Ground fault</li> </ul> </li> <li>• Overpressure</li> <li>• Bypass mode</li> <li>• VFD failure</li> </ul>

\*\*Tornatech reserves the right to use any of these three alarm points for special specific application requirements.



<p><b>ViZiTouch V2.1 Operator Interface</b></p>	<ul style="list-style-type: none"> <li>• Embedded microcomputer with software PLC logic</li> <li>• 7.0" color touch screen (HMI technology)</li> <li>• Upgradable software</li> <li>• Multi-language</li> </ul>		
<p><b>Communication Protocol Capability</b></p>	<ul style="list-style-type: none"> <li>• Protocol: Modbus</li> <li>• Connection type: Shielded female connector RJ45</li> <li>• Frame Format: TCP/IP</li> <li>• Addresses: See Technical Bulletin - Modbus TCP/IP Communication Protocol for Electric Fire Pump Controllers with Automatic Transfer Switch</li> </ul>		
<p><b>Operation</b></p>	<p><b>Automatic Start</b></p>	<ul style="list-style-type: none"> <li>• Start on pressure drop</li> <li>• Remote start signal from automatic device</li> <li>• Deluge valve start</li> </ul>	
	<p><b>Manual Start</b></p>	<ul style="list-style-type: none"> <li>• Start pushbutton</li> <li>• Run test pushbutton</li> <li>• Remote start from manual device</li> </ul>	
	<p><b>Stopping</b></p>	<ul style="list-style-type: none"> <li>• Manual with Stop pushbutton</li> <li>• Automatic after expiration of minimum run timer ***</li> </ul>	
	<p><b>Timers</b></p>	<p>Field Adjustable &amp; Visual Countdown</p>	<ul style="list-style-type: none"> <li>• Minimum run timer ***(off delay)</li> <li>• Sequential start timer (on delay)</li> <li>• Periodic test timer</li> </ul>
	<p><b>Actuation</b></p>	<p>Visual Indication</p>	<ul style="list-style-type: none"> <li>• Pressure</li> <li>• Non-pressure</li> </ul>
	<p><b>Mode</b></p>		<ul style="list-style-type: none"> <li>• Automatic</li> <li>• Non-automatic</li> </ul>

\*\*\*Can only be used if approved by the AHJ



### VPx Series Full Service Variable Speed Electric Fire Pump Controller with Automatic Power Transfer Switch

A4	Flow switch provision
A8	Foam pump application w/o pressure transducer and run test solenoid valve.
A9	Low zone pump control function
A10	Middle zone pump control function
A11	High zone pump control function
A13	Non-pressure actuated controller w/o pressure transducer and run test solenoid valve
A16	Lockout/interlock circuit from equipment installed inside the pump room
B11	Built in alarm panel (120V.AC supervisory power) providing indication for: • Audible alarm & silence pushbutton for motor run, phase reversal, loss of phase. • Pilot lights for loss of phase & supervisory power available
B11B	Built in alarm panel same as B11 but 220-240VAC supervisory power
B19A	High motor temperature c/w thermostat relay and alarm contacts (DPDT)
B19B	High motor temperature c/w PT100 relay and alarm contacts (DPDT)
B21	Ground fault alarm detection c/w visual indication and alarm contact (DPDT)
C1	Extra motor run alarm contact (DPDT)
C4	Periodic test alarm contact (DPDT)
C6	Low discharge pressure alarm contact (DPDT)
C7	Low pump room temperature alarm contact (DPDT)
C10	Low water reservoir level alarm contact (DPDT)
C11	High electric motor temperature alarm contact (DPDT)
C12	High electric motor vibration c/w visual indication and alarm contact (DPDT)
C14	Pump on demand / automatic start alarm contact (DPDT)
C15	Pump fail to start alarm contact (DPDT)
C16	Control voltage healthy alarm contact (DPDT)
C17	Flow meter valve loop open c/w visual indication and alarm contact (DPDT)
C18	High water reservoir level c/w visual indication and alarm contact (DPDT)
C19	Emergency start alarm contact (DPDT)

C20	Manual start alarm contact (DPDT)
C21	Deluge valve start alarm contact (DPDT)
C22	Remote automatic start alarm contact (DPDT)
C23	Remote manual start alarm contact (DPDT)
C24	High pump room temperature alarm contact (DPDT)
C25	Second set of standard alarm contacts (DPDT) (Typical for city of Los Angeles and Denver)
Cx	Additional visual and alarm contact (Specify function) (DPDT)
D1	Low suction pressure transducer for fresh water rated at 0-500PSI with visual indication and alarm contact
D1A	Low suction pressure transducer for sea water rated at 0-500PSI with visual indication and alarm contact
D5	Pressure transducer and run test solenoid valve for fresh water rated for 0-500PSI (for factory calibration purposes only)
D5D	Pressure transducer and run test solenoid valve for sea water rated for 0-500PSI
D14	Anti-condensation heater & thermostat
D14A	Anti-condensation heater & humidistat
D14B	Anti-condensation heater & thermostat & humidistat
D15	Tropicalization
D27	Motor heater connection (external single phase power source and heater on/off contact)
D27A	Motor heater connection (internal single phase power source and heater on/off contact)
D28	Customized drawing set
D34A	Field programmable I/O board - 5 Input / 5 output
D36	Redundant pressure transducer for fresh water rated for 0-500PSI
D36A	Redundant pressure transducer for sea water rated for 0-500PSI
D43	Seismic Certification compliant to CBC 2019, IBC 2018 rigid base/wall mounted only
D44	Special Seismic Certification compliant to OSHPD rigid base/wall mounted only

Note: Options chosen from this page are not electrically represented on the wiring schematics in this submittal package.



E1	Permanent load shedding contacts
E2	Temporary pump motor start period load shedding contacts
E3	Temporary & permanent load shedding contacts
F2	Anti condensation heater & thermostat (alternate power section)
F2A	Anti condensation heater & humidistat (alternate power section)
F2B	Anti condensation heater & thermostat & humidistat (alternate power section)

Additional Options:

---



---



---



---



---

Note: Options chosen from this page are not electrically represented on the wiring schematics in this submittal package.

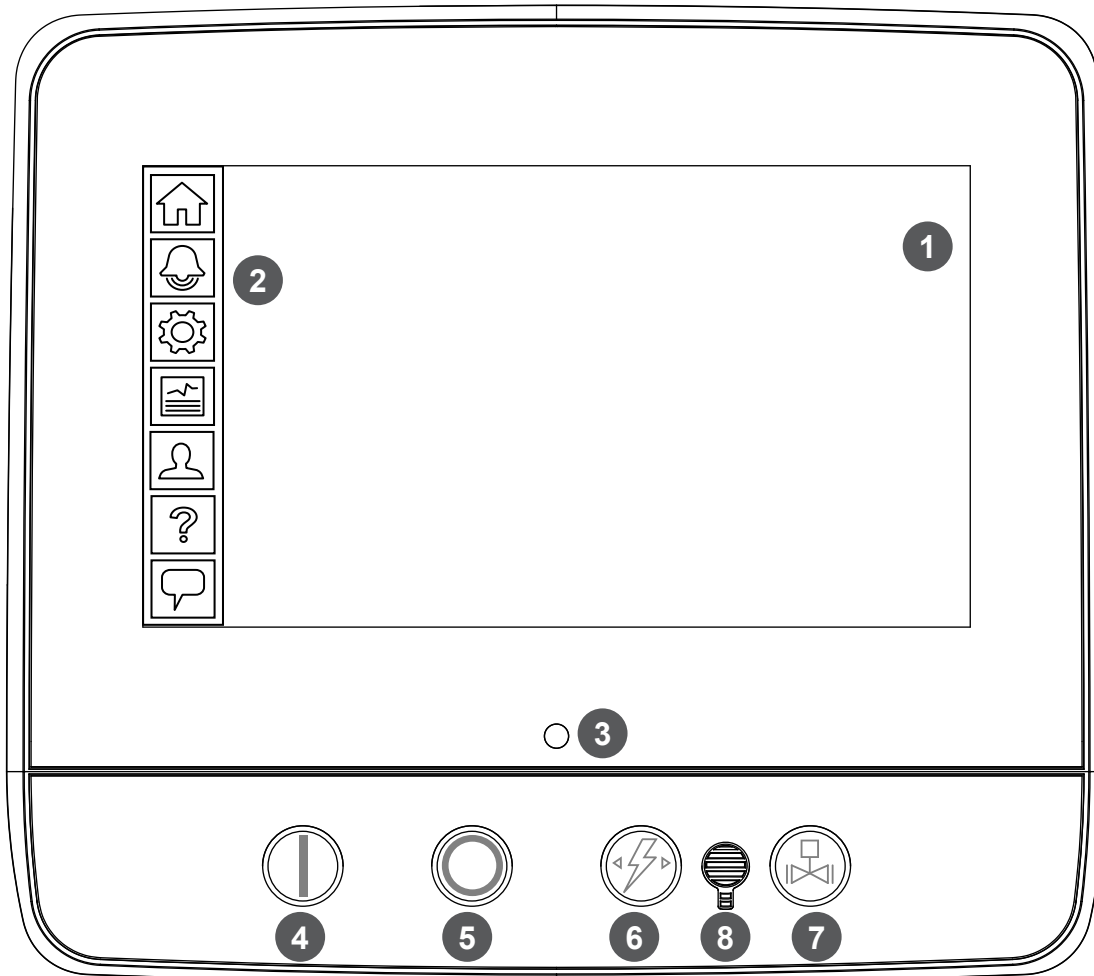
**ViZiTouch V2.1 Operator Interface**

- |                        |                                 |
|------------------------|---------------------------------|
| 1 - Color touch screen | 3 - Power LED (3 colors)        |
| 2 - Onscreen menu      | 4 - START button                |
| • HOME page            | 5 - STOP button                 |
| • ALARM page           | 6 - TRANSFER SWITCH TEST button |
| • CONFIGURATION page   | 7 - RUN TEST button             |
| • HISTORY page         | 8 - Alarm buzzer                |
| • SERVICE page         |                                 |
| • MANUAL page          |                                 |
| • LANGUAGES page       |                                 |



© Tornatech, Inc. Not for construction.  
Subject to change without notice.

	BY	DD/MM/YY
DRAWN BY	DDS	11/05/26
FINAL APPROVAL	FC	11/05/26

# ELECTRIC FIRE PUMP CONTROLLER WITH AUTOMATIC TRANSFER SWITCH

**MODEL: VPS + VPU**

BUILT TO THE LATEST EDITION OF THE NFPA20 & NFPA70



THIRD ANGLE  
PROJECTION

DRAWING NUMBER	VPX-DI816 /E
DWG REV. 0	
SHEET 1 OF 1	

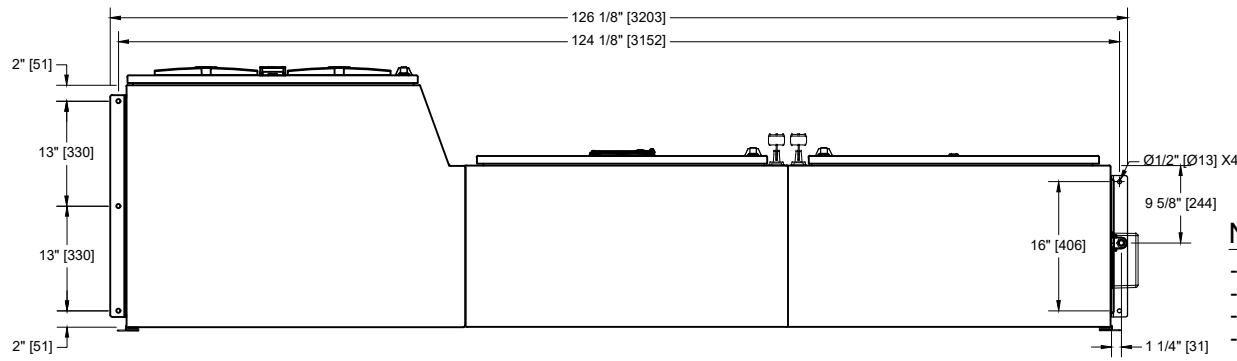
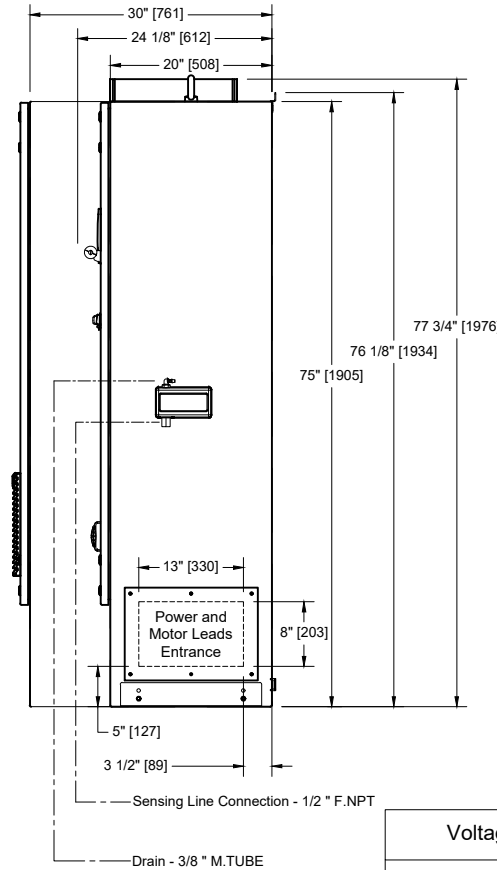
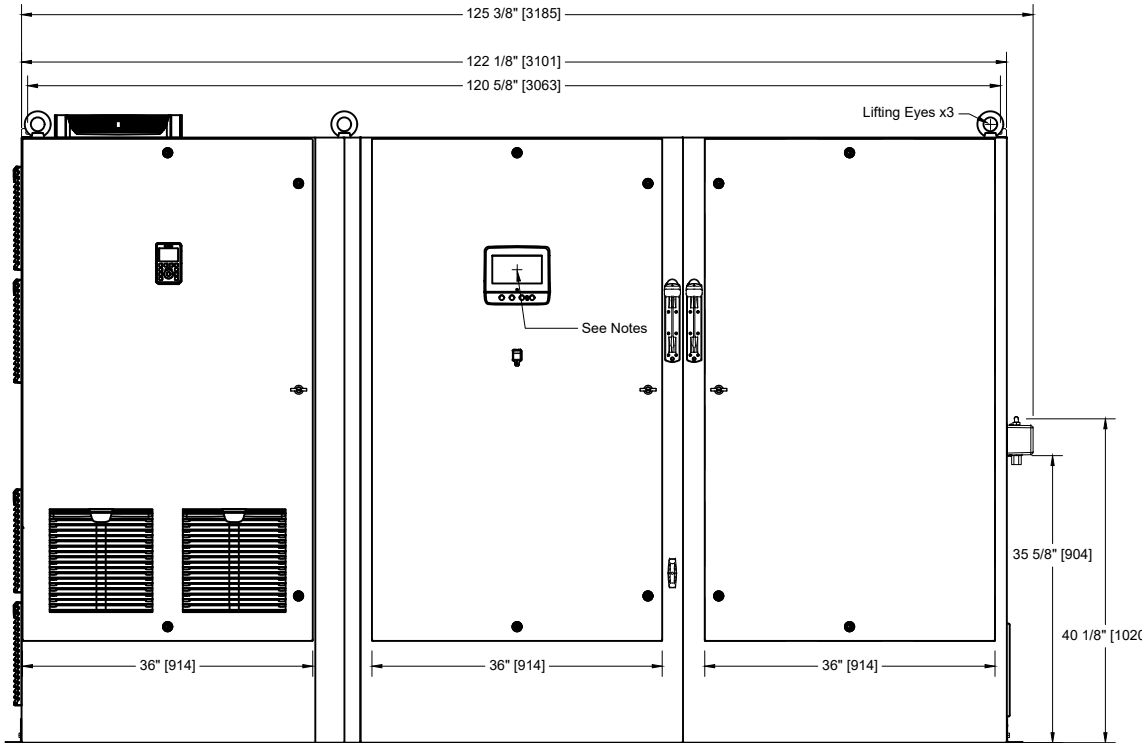

Voltage	Min HP	Max HP
380 - 400 - 415	200	
440 - 480	250	

**Notes:**

- Standard: NEMA 12
- Standard paint : textured red RAL 3002.
- All dimensions are in inches [millimeters].
- Center of screen: 29-5/8" [751] from bottom (no feet).
- Side conduit entrance through removable gland plate recommended.
- Use watertight conduit and connector only.
- Protect equipment against drilling chips.
- Door swing equal to door width.



© Tornatech, Inc. Not for construction.  
Subject to change without notice.

BY DD/MM/YY	
DRAWN BY	DDS 11/05/26
FINAL APPROVAL	FC 11/05/26

# ELECTRIC FIRE PUMP CONTROLLER

## VARIABLE SPEED / SOFT STARTER BYPASS STARTING WITH AUTOMATIC TRANSFER SWITCH

**MODEL: VPS+VPU**

BUILT TO THE LATEST EDITION OF THE NFPA20 & NFPA70



DRAWING NUMBER	VPS-WS813 /E
DWG REV. 0	
SHEET 1 OF 4	

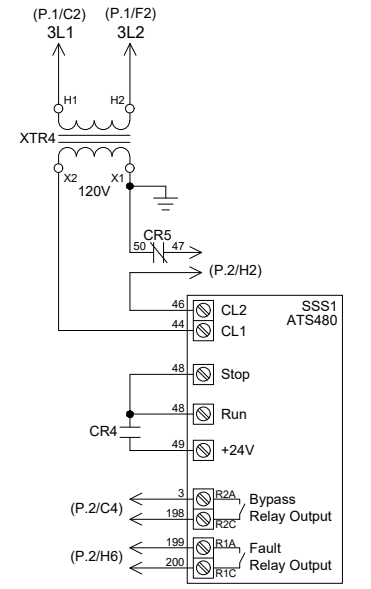
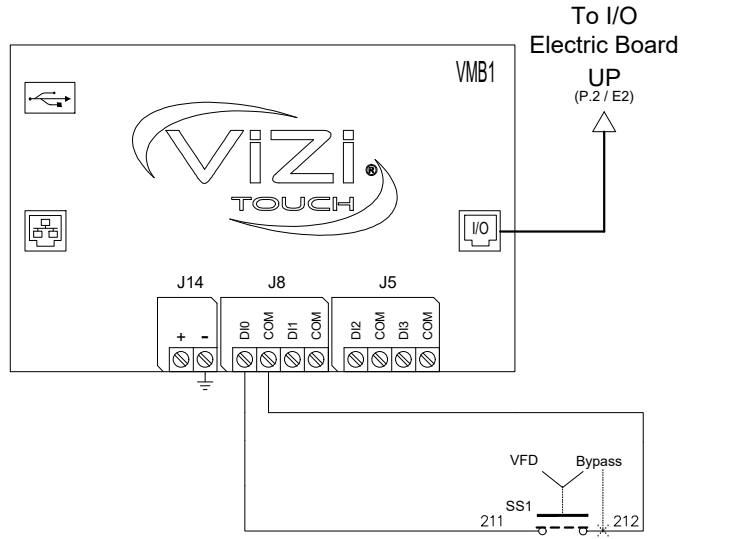
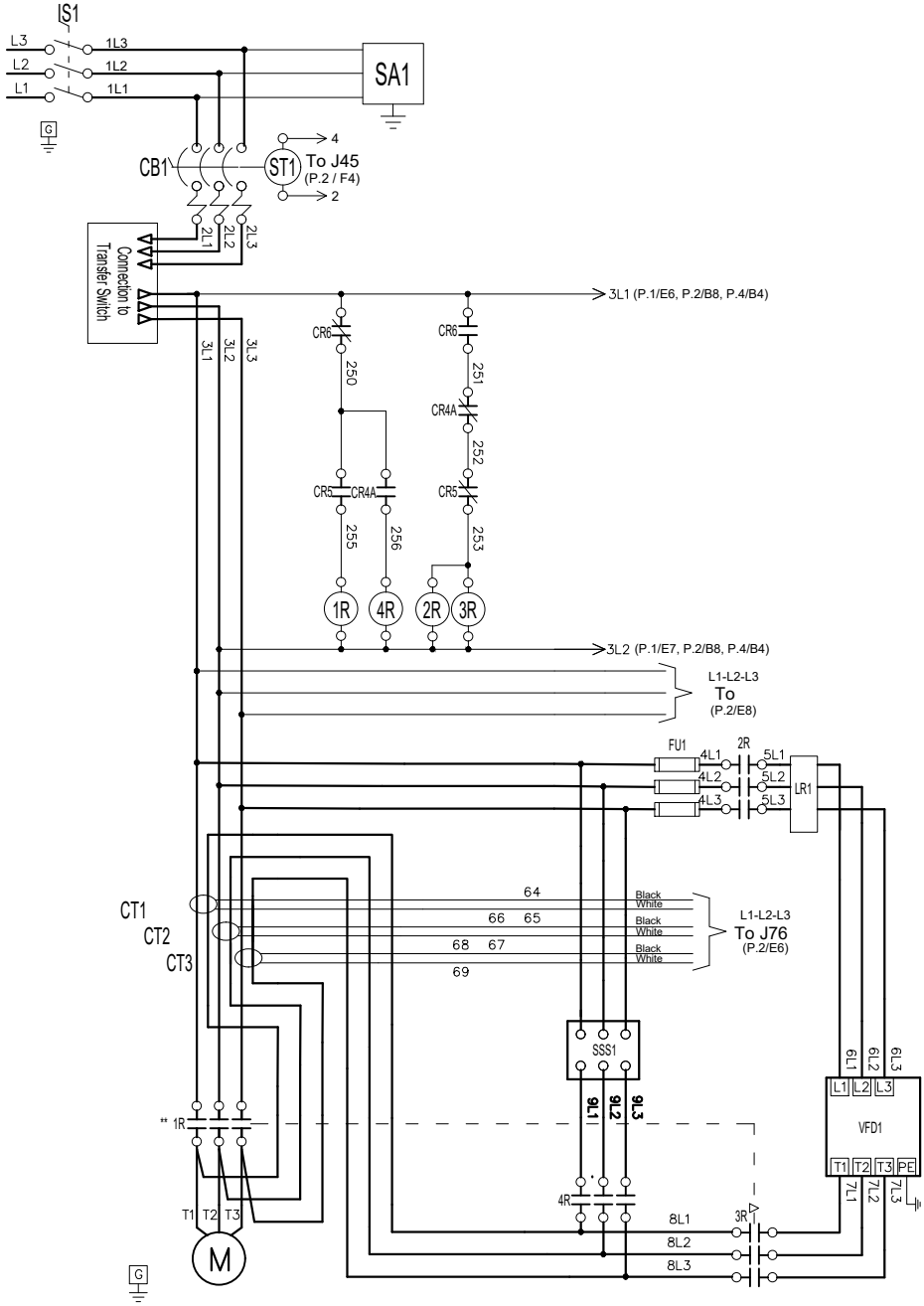

Legend	
R	Contact
CB	Circuit Breaker
CR	Control Relay
CT	Current Transformer
EB	Electric I/O Board
EXB	Expansion Board
F	Ferrite
FAN	Cooling Fan
FU	Fuse
IS	Isolating Switch
J	Jumper
LS	Limit Switch
LR	Line Reactor
PS	Power Supply
PT	Pressure Transducer
SA	Surge Arrester
SSS	Soft Starter
ST	Shunt Trip
SV	Solenoid Valve
VMB	Main Board
XTR	Transformer
VFD	Variable Frequency Drive

\*\* Contact closes when emergency start is in "ON" position.



© Tornatech, Inc. Not for construction.  
Subject to change without notice.

BY		DD/MM/YY	
DRAWN BY	DDS	11/05/26	
FINAL APPROVAL	FC	11/05/26	

# ELECTRIC FIRE PUMP CONTROLLER

## VARIABLE SPEED / SOFT STARTER BYPASS STARTING WITH AUTOMATIC TRANSFER SWITCH

### MODEL: VPS+VPU

BUILT TO THE LATEST EDITION OF THE NFPA20 & NFPA70



DRAWING NUMBER	VPS-WS813 / E
DWG REV. 0	
SHEET 2 OF 4	

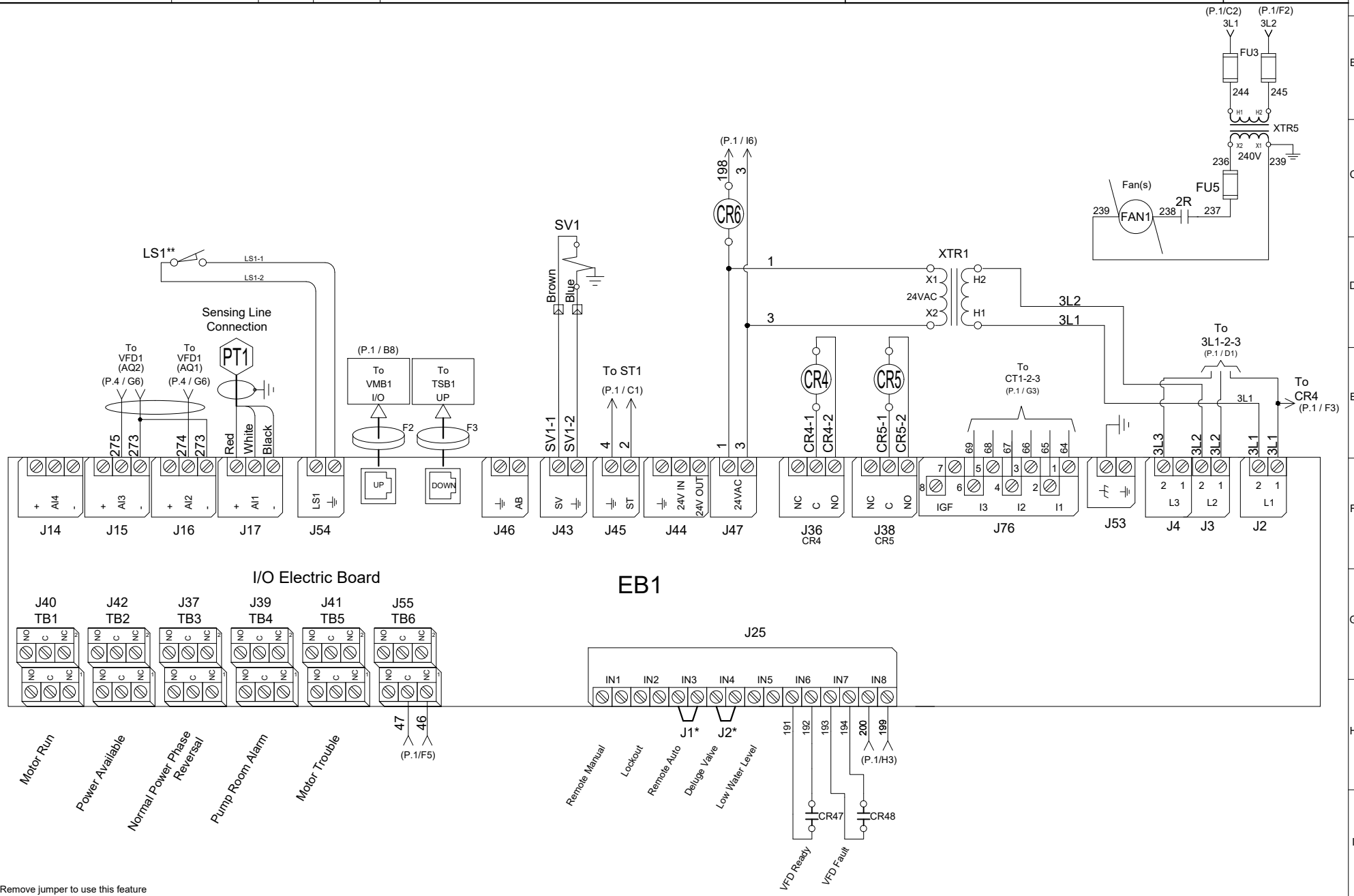

\* Remove jumper to use this feature  
\*\* Contact closes when emergency start is in "ON" position



© Tornatech, Inc. Not for construction.  
Subject to change without notice.

BY		DD/MM/YY
DRAWN BY	DDS	11/05/26
FINAL APPROVAL	FC	11/05/26

# ELECTRIC FIRE PUMP CONTROLLER

## VARIABLE SPEED / SOFT STARTER BYPASS STARTING WITH AUTOMATIC TRANSFER SWITCH

**MODEL: VPS+VPU**

BUILT TO THE LATEST EDITION OF THE NFPA20 & NFPA70



DRAWING NUMBER	VPS-WS813 /E
DWG REV. 0	
SHEET 3 OF 4	

### Expansion Board 1

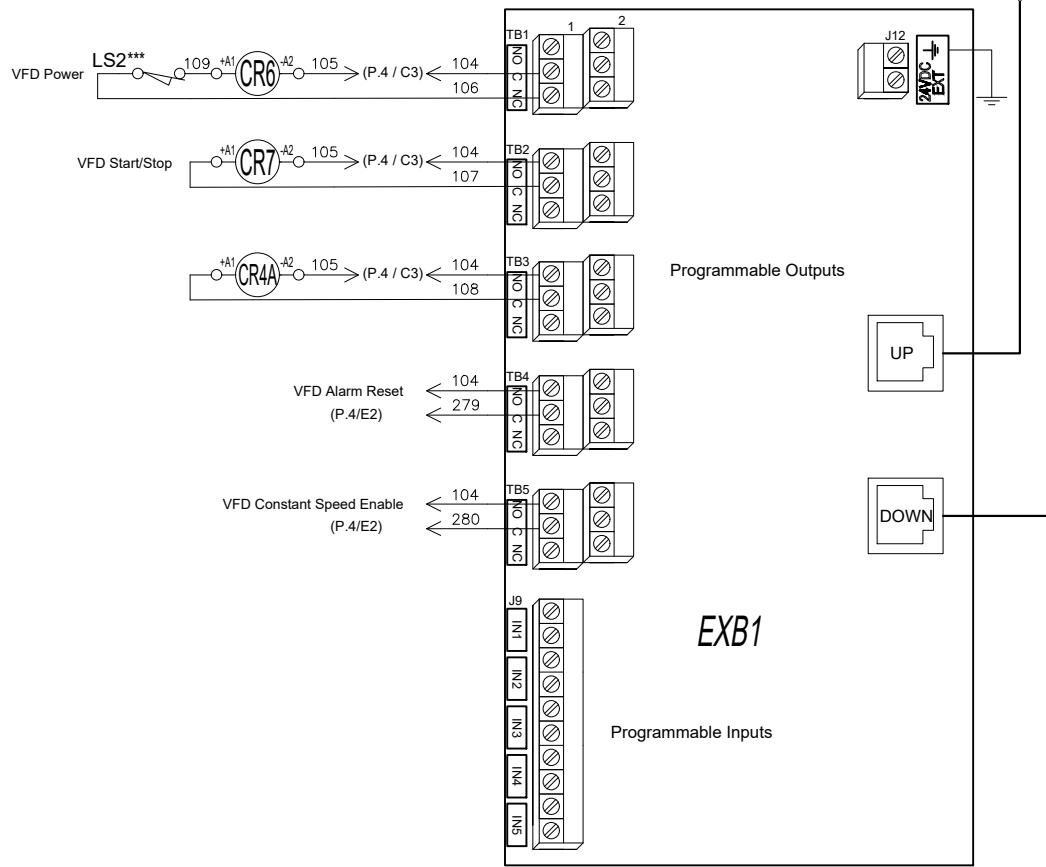

### Expansion Board 2

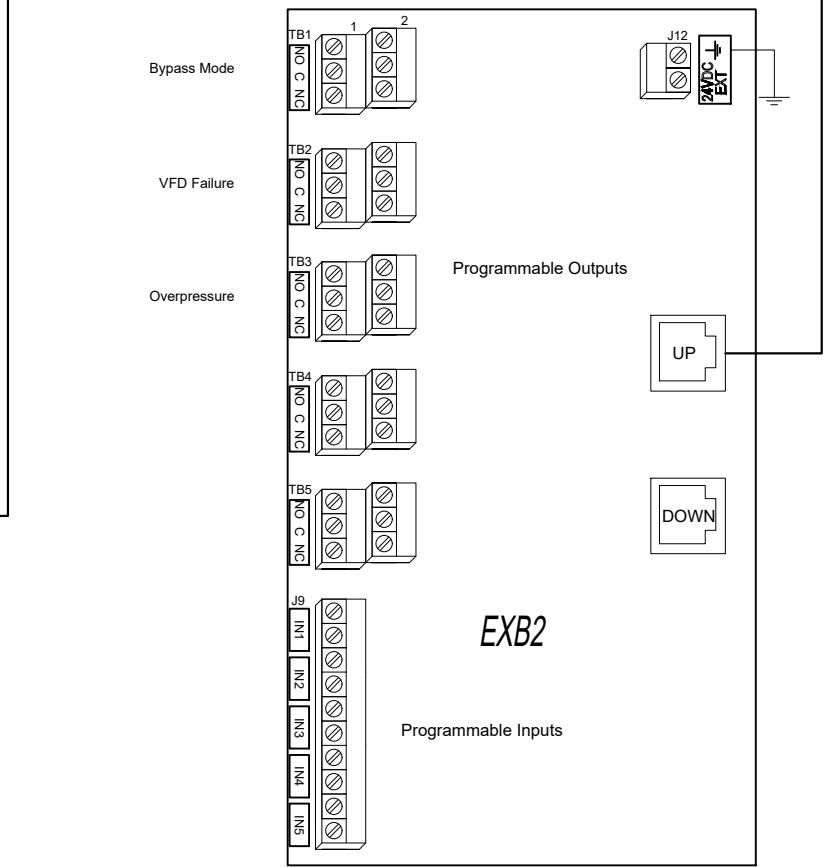

\*\*\* Contact opens when emergency start is in "ON" position



© Tornatech, Inc. Not for construction.  
Subject to change without notice.

BY		DD/MM/YY
DRAWN BY	DDS	11/05/26
FINAL APPROVAL	FC	11/05/26

# ELECTRIC FIRE PUMP CONTROLLER

## VARIABLE SPEED / SOFT STARTER BYPASS STARTING WITH AUTOMATIC TRANSFER SWITCH

### MODEL: VPS+VPU

BUILT TO THE LATEST EDITION OF THE NFPA20 & NFPA70



DRAWING NUMBER	VPS-WS813 /E
DWG REV.	0
SHEET	4 OF 4

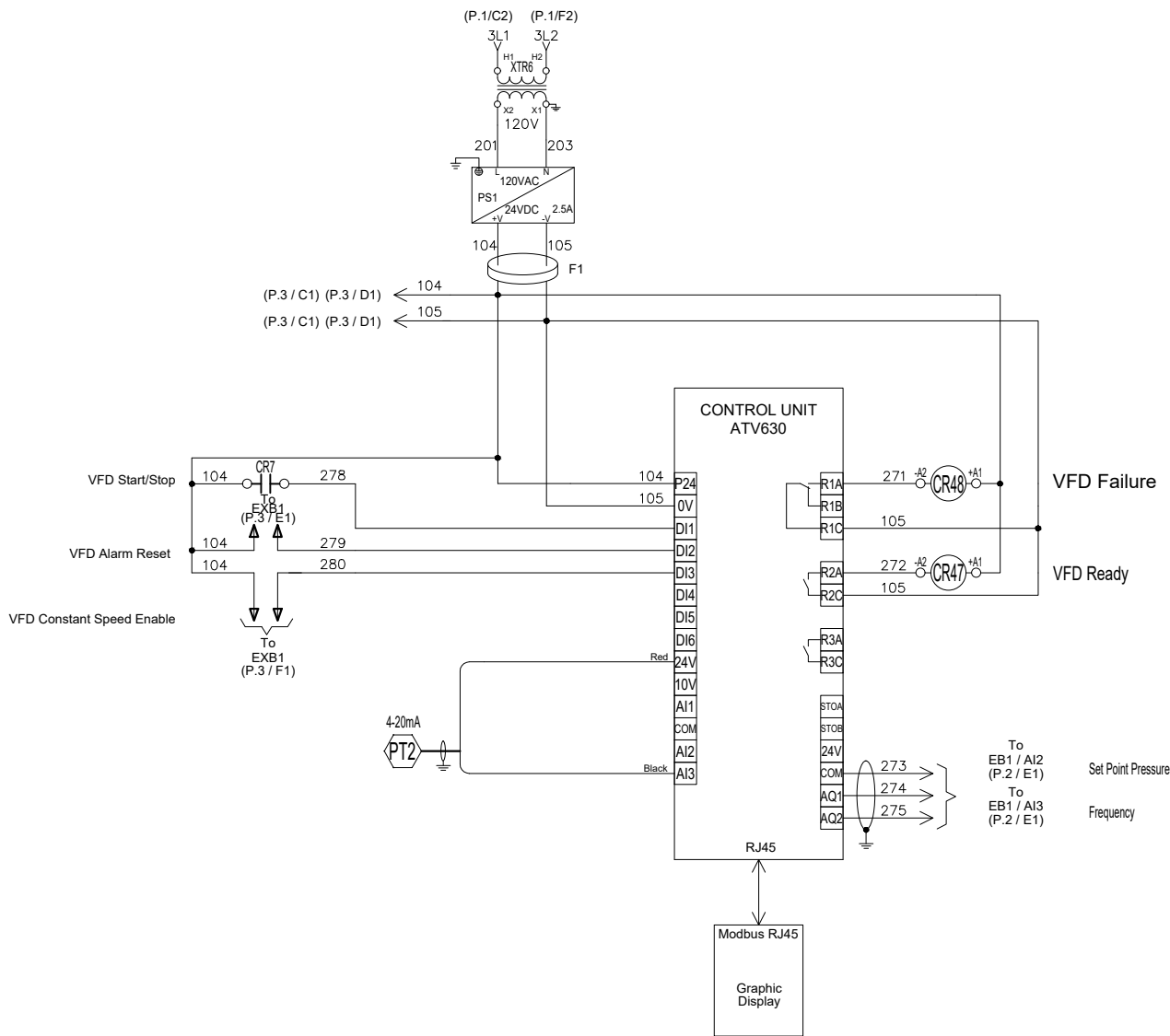



BY DD/MM/YY  
 DRAWN BY ZS 21/07/23  
 FINAL APPROVAL FC 21/07/23

# AUTOMATIC TRANSFER SWITCH FOR ELECTRIC FIRE PUMP CONTROLLER

**MODEL: VPU**

BUILT TO THE LATEST EDITION OF THE NFPA20 & NFPA70



DRAWING NUMBER  
**VPU-WS800/E**  
 DWG REV. 0  
 SHEET 1 OF 1

© Tornatech, Inc. Not for construction.  
 Subject to change without notice.

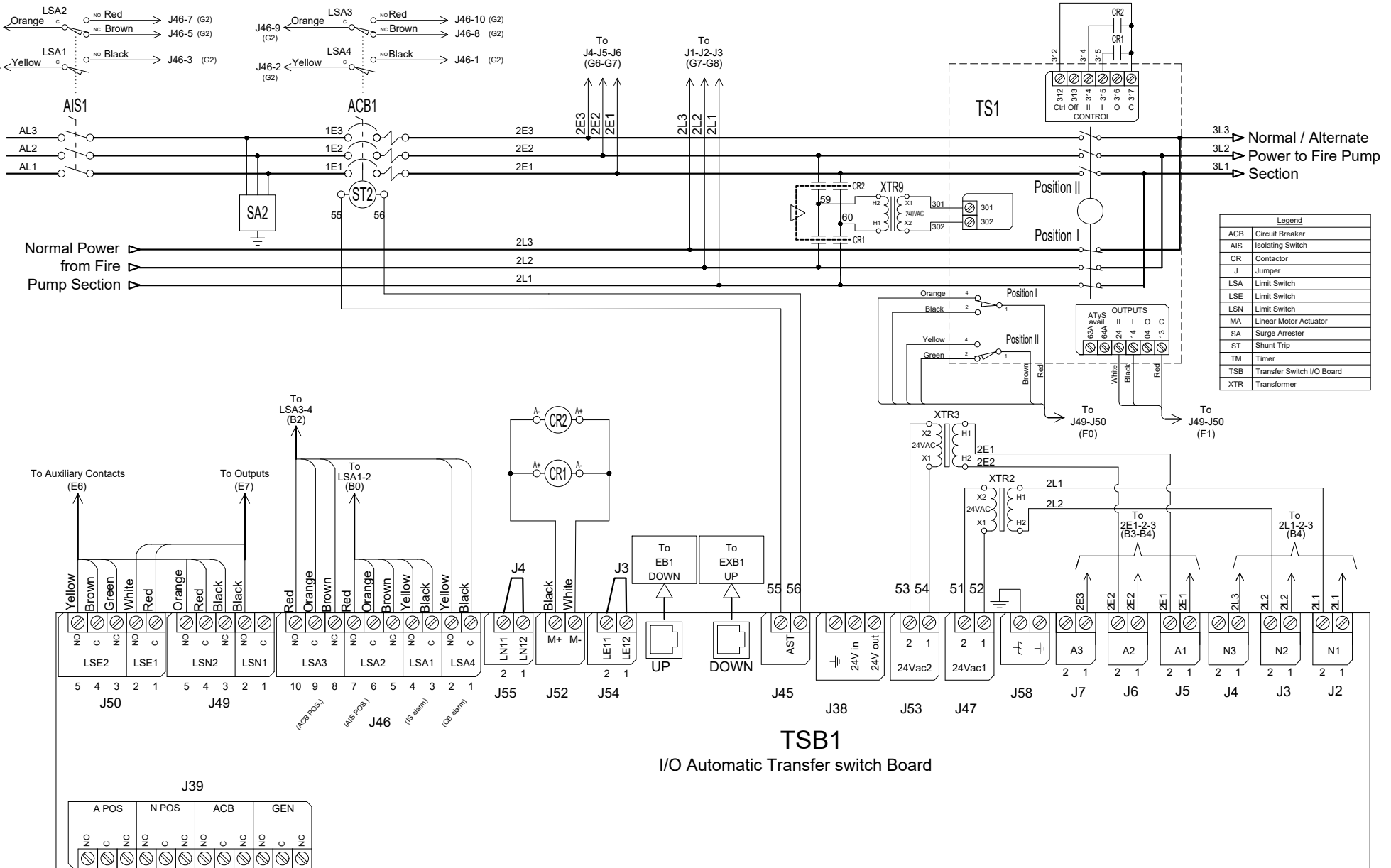

Legend	
ACB	Circuit Breaker
AIS	Isolating Switch
CR	Contactors
J	Jumper
LSA	Limit Switch
LSE	Limit Switch
LSN	Limit Switch
MA	Linear Motor Actuator
SA	Surge Arrester
ST	Shunt Trip
TM	Timer
TSB	Transfer Switch I/O Board
XTR	Transformer



© Tornatech, Inc. Not for construction.  
Subject to change without notice.

BY		DD/MM/YY
DRAWN BY	ZS	10/07/23
FINAL APPROVAL	FC	10/07/23

# ELECTRIC FIRE PUMP CONTROLLER

**MODEL: VPA / VPS**

BUILT TO THE LATEST EDITION OF THE NFPA20 & NFPA70



DRAWING NUMBER	VPX-TD800 / E
DWG REV. 0	
SHEET 1 OF 1	

## COPPER CONDUCTORS for Isolating Switch (IS1).

Field Wiring According to Bending Space (AWG or MCM). Terminals L1 - L2 - L3

Bending Space	5" (127 mm)							8" (203 mm)			12" (305 mm)		
	HP	5	7.5	10	15	20	25	30	40	50	60	75	100
200	1x (10 to 1/0)	1x (8 to 1/0)	1x (8 to 1/0)	1x (6 to 1/0)	1x (4 to 1/0)	1x (3 to 1/0)	1x (2 to 1/0)	1x (1/0 to 3/0)	1x (3/0 to 250)	1x (4/0 to 250)	2x (1/0 to 500)	-----	
208	1x (10 to 1/0)	1x (8 to 1/0)	1x (8 to 1/0)	1x (6 to 1/0)	1x (4 to 1/0)	1x (3 to 1/0)	1x (2 to 1/0)	1x (1/0 to 3/0)	1x (3/0 to 250)	1x (4/0 to 250)	2x (1/0 to 500)	2x (2/0 to 500)	
220 to 240	1x (10 to 1/0)	1x (10 to 1/0)	1x (8 to 1/0)	1x (6 to 1/0)	1x (4 to 1/0)	1x (4 to 1/0)	1x (3 to 1/0)	1x (1 to 3/0)	1x (2/0 to 3/0)	1x (3/0 to 250)	1x (250)	2x (2/0 to 500)	
380 to 416	1x (10 to 1/0)	1x (10 to 1/0)	1x (10 to 1/0)	1x (8 to 1/0)	1x (8 to 1/0)	1x (6 to 1/0)	1x (6 to 1/0)	1x (4 to 1/0)	1x (3 to 1/0)	1x (3 to 1/0)	1x (1/0 to 3/0)	1x (3/0 to 250)	
440 to 480	1x (10 to 1/0)	1x (10 to 1/0)	1x (10 to 1/0)	1x (10 to 1/0)	1x (8 to 1/0)	1x (8 to 1/0)	1x (6 to 1/0)	1x (6 to 1/0)	1x (4 to 1/0)	1x (3 to 1/0)	1x (1 to 3/0)	1x (2/0 to 3/0)	
600	1x (10 to 1/0)	1x (10 to 1/0)	1x (10 to 1/0)	1x (10 to 1/0)	1x (10 to 1/0)	1x (8 to 1/0)	1x (8 to 1/0)	1x (6 to 1/0)	1x (6 to 1/0)	1x (4 to 1/0)	1x (3 to 1/0)	1x (1 to 3/0)	
											5" (127 mm)	8" (203 mm)	

## Power Terminals

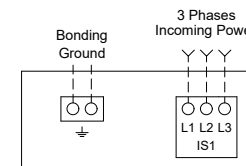

Bending Space	12" (305 mm)		16" (406 mm)						
	HP	125	150	200	250	300	350	400	450
380 to 416	1x (250)	2x (1/0 to 500)	2x (3/0 to 500)	2x (4/0 to 500)	2x (300 to 500)	2x (400 to 500)	-----	-----	
440 to 480	1x (3/0 to 250)	1x (4/0 to 250)	2x (1/0 to 500)	2x (3/0 to 500)	2x (4/0 to 500)	2x (300 to 500)	2x (350 to 500)	2x (400 to 500)	
Bending Space	8" (203 mm)		12" (305 mm)						

## ALUMINUM CONDUCTORS for Isolating Switch (IS1).

Field Wiring According to Bending Space (AWG or MCM). Terminals L1 - L2 - L3

Bending Space	5" (127 mm)							8" (203 mm)		10" (254 mm)	12" (305 mm)		
	HP	5	7.5	10	15	20	25	30	40	50	60	75	100
200	1x (10 to 1/0)	1x (6 to 1/0)	1x (6 to 1/0)	1x (4 to 1/0)	1x (3 to 1/0)	1x (1 to 1/0)	1x (1/0)	1x (3/0)	1x (4/0 to 250)	1x (300)** or 1x (250) 90°C*	2x (2/0 to 500)	-----	
208	1x (10 to 1/0)	1x (6 to 1/0)	1x (6 to 1/0)	1x (4 to 1/0)	1x (3 to 1/0)	1x (1 to 1/0)	1x (1/0)	1x (3/0)	1x (4/0 to 250)	1x (300)** or 1x (250) 90°C*	2x (2/0 to 500)	2x (4/0 to 500)	
220 to 240	1x (10 to 1/0)	1x (8 to 1/0)	1x (6 to 1/0)	1x (4 to 1/0)	1x (3 to 1/0)	1x (2 to 1/0)	1x (1 to 1/0)	1x (2/0 to 3/0)	1x (3/0) 90°C*	1x (250)	1x (350)** N/A	2x (3/0 to 500)	
380 to 416	1x (10 to 1/0)	1x (10 to 1/0)	1x (10 to 1/0)	1x (6 to 1/0)	1x (6 to 1/0)	1x (4 to 1/0)	1x (4 to 1/0)	1x (2 to 1/0)	1x (1 to 1/0)	1x (1/0)	1x (3/0)	1x (250 to 350)	
440 to 480	1x (10 to 1/0)	1x (10 to 1/0)	1x (10 to 1/0)	1x (8 to 1/0)	1x (6 to 1/0)	1x (6 to 1/0)	1x (6 to 1/0)	1x (4 to 1/0)	1x (2 to 1/0)	1x (1 to 1/0)	1x (1/0 to 3/0)	1x (3/0)	
600	1x (10 to 1/0)	1x (10 to 1/0)	1x (10 to 1/0)	1x (10 to 1/0)	1x (8 to 1/0)	1x (6 to 1/0)	1x (6 to 1/0)	1x (4 to 1/0)	1x (4 to 1/0)	1x (2 to 1/0)	1x (1 to 1/0)	1x (2/0 to 3/0)	
											5" (127 mm)	8" (203 mm)	

Bending Space	12" (305 mm)		16" (406 mm)						
	HP	125	150	200	250	300	350	400	450
380 to 416	1x (350)** N/A	2x (3/0 to 500)	2x (4/0 to 500)	2x (300 to 500)	2x (500)	3x (300 to 500)** 2x (500) 90°C*	-----	-----	
440 to 480	1x (250)	1x (300 to 350)** 1x (250) 90°C*	2x (3/0 to 500)	2x (250 to 500)	2x (300 to 500)	2x (400 to 500)	2x (500)	2x (500) 90°C*	
Bending Space	8" (203 mm)		12" (305 mm)						

\*For standard enclosure, use 90°C aluminium wire. Consult Factory for Use of Conductors Rated Lower than 90°C.

\*\* Consult Factory

### Notes:

- 1 - For proper wire sizing, refer to NFPA70 and NEC (USA) or CEC (Canada) or local code.
- 2 - Controller suitable for service entrance in USA.
- 3 - For more accurate motor connections refer to motor manufacturer or motor nameplate.
- 4 - Controller is phase sensitive. Incoming lines must be connected in IS sequence.

Drawing for information only.  
Manufacturer reserves the right to modify this drawing without notice.  
Contact manufacturer for "As Built" drawing.



© Tornatech, Inc. Not for construction.  
Subject to change without notice.

BY		DD/MM/YY
DRAWN BY	ZS	10/07/23
FINAL APPROVAL	FC	10/07/23

# AUTOMATIC TRANSFER SWITCH FOR ELECTRIC FIRE PUMP CONTROLLER

**MODEL: VPU**

BUILT TO THE LATEST EDITION OF THE NFPA20 & NFPA70



DRAWING NUMBER  
**VPU-TD802/E**  
DWG REV. 0  
SHEET 1 OF 1

**COPPER CONDUCTORS** for Isolating Switch (AIS1).

Field Wiring According to Bending Space (AWG or MCM). Terminals AL1 - AL2 - AL3

Bending Space	5" (127 mm)							8" (203 mm)			12" (305 mm)		
	HP Voltage	5	7.5	10	15	20	25	30	40	50	60	75	100
200	1x (10 to 1/0)	1x (8 to 1/0)	1x (8 to 1/0)	1x (6 to 1/0)	1x (4 to 1/0)	1x (3 to 1/0)	1x (2 to 1/0)	1x (1/0 to 3/0)	1x (3/0 to 250)	1x (4/0 to 250)	2x (1/0 to 500)	-----	
208	1x (10 to 1/0)	1x (8 to 1/0)	1x (8 to 1/0)	1x (6 to 1/0)	1x (4 to 1/0)	1x (3 to 1/0)	1x (2 to 1/0)	1x (1/0 to 3/0)	1x (3/0 to 250)	1x (4/0 to 250)	2x (1/0 to 500)	2x (2/0 to 500)	
220 to 240	1x (10 to 1/0)	1x (10 to 1/0)	1x (8 to 1/0)	1x (6 to 1/0)	1x (4 to 1/0)	1x (4 to 1/0)	1x (3 to 1/0)	1x (1 to 3/0)	1x (2/0 to 3/0)	1x (3/0 to 250)	1x (250)	2x (2/0 to 500)	
380 to 416	1x (10 to 1/0)	1x (10 to 1/0)	1x (10 to 1/0)	1x (8 to 1/0)	1x (8 to 1/0)	1x (6 to 1/0)	1x (6 to 1/0)	1x (4 to 1/0)	1x (3 to 1/0)	1x (3 to 1/0)	1x (1/0 to 3/0)	1x (3/0 to 250)	
440 to 480	1x (10 to 1/0)	1x (10 to 1/0)	1x (10 to 1/0)	1x (10 to 1/0)	1x (8 to 1/0)	1x (8 to 1/0)	1x (6 to 1/0)	1x (6 to 1/0)	1x (4 to 1/0)	1x (3 to 1/0)	1x (1 to 3/0)	1x (2/0 to 3/0)	
600	1x (10 to 1/0)	1x (10 to 1/0)	1x (10 to 1/0)	1x (10 to 1/0)	1x (10 to 1/0)	1x (8 to 1/0)	1x (8 to 1/0)	1x (6 to 1/0)	1x (6 to 1/0)	1x (4 to 1/0)	1x (3 to 1/0)	1x (1 to 3/0)	
											5" (127 mm)	8" (203 mm)	

**Power Terminals**

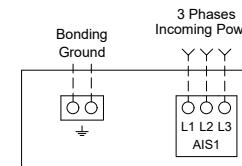

Bending Space	12" (305 mm)		16" (406 mm)						
	HP Voltage	125	150	200	250	300	350	400	450
380 to 416	1x (250)	2x (1/0 to 500)	2x (3/0 to 500)	2x (4/0 to 500)	2x (300 to 500)	2x (400 to 500)	-----	-----	
440 to 480	1x (3/0 to 250)	1x (4/0 to 250)	2x (1/0 to 500)	2x (3/0 to 500)	2x (4/0 to 500)	2x (300 to 500)	2x (350 to 500)	2x (400 to 500)	
Bending Space	8" (203 mm)		12" (305 mm)						

**ALUMINUM CONDUCTORS** for Isolating Switch (AIS1).

Field Wiring According to Bending Space (AWG or MCM). Terminals AL1 - AL2 - AL3

Bending Space	5" (127 mm)							8" (203 mm)		10" (254 mm)	12" (305 mm)		
	HP Voltage	5	7.5	10	15	20	25	30	40	50	60	75	100
200	1x (10 to 1/0)	1x (6 to 1/0)	1x (6 to 1/0)	1x (4 to 1/0)	1x (3 to 1/0)	1x (1 to 1/0)	1x (1/0)	1x (3/0)	1x (4/0 to 250)	1x (300)** or 1x (250) 90°C*	2x (2/0 to 500)	-----	
208	1x (10 to 1/0)	1x (6 to 1/0)	1x (6 to 1/0)	1x (4 to 1/0)	1x (3 to 1/0)	1x (1 to 1/0)	1x (1/0)	1x (3/0)	1x (4/0 to 250)	1x (300)** or 1x (250) 90°C*	2x (2/0 to 500)	2x (4/0 to 500)	
220 to 240	1x (10 to 1/0)	1x (8 to 1/0)	1x (6 to 1/0)	1x (4 to 1/0)	1x (3 to 1/0)	1x (2 to 1/0)	1x (1 to 1/0)	1x (2/0 to 3/0)	1x (3/0) 90°C*	1x (250)	1x (350)** or N/A	2x (3/0 to 500)	
380 to 416	1x (10 to 1/0)	1x (10 to 1/0)	1x (10 to 1/0)	1x (6 to 1/0)	1x (6 to 1/0)	1x (4 to 1/0)	1x (4 to 1/0)	1x (2 to 1/0)	1x (1 to 1/0)	1x (1/0)	1x (3/0)	1x (250 to 350)	
440 to 480	1x (10 to 1/0)	1x (10 to 1/0)	1x (10 to 1/0)	1x (8 to 1/0)	1x (6 to 1/0)	1x (6 to 1/0)	1x (6 to 1/0)	1x (4 to 1/0)	1x (2 to 1/0)	1x (1 to 1/0)	1x (1/0 to 3/0)	1x (3/0)	
600	1x (10 to 1/0)	1x (10 to 1/0)	1x (10 to 1/0)	1x (10 to 1/0)	1x (8 to 1/0)	1x (6 to 1/0)	1x (6 to 1/0)	1x (4 to 1/0)	1x (4 to 1/0)	1x (2 to 1/0)	1x (1 to 1/0)	1x (2/0 to 3/0)	
											5" (127 mm)	8" (203 mm)	

Bending Space	12" (305 mm)		16" (406 mm)						
	HP Voltage	125	150	200	250	300	350	400	450
380 to 416	1x (350)**	2x (3/0 to 500)	2x (4/0 to 500)	2x (300 to 500)	2x (500)	3x (300 to 500)**	2x (500) 90°C*	-----	-----
440 to 480	1x (250)	1x (300 to 350)**	2x (3/0 to 500)	2x (250 to 500)	2x (300 to 500)	2x (400 to 500)	2x (500)	2x (500) 90°C*	
Bending Space	8" (203 mm)		12" (305 mm)						

\*For standard enclosure, use 90°C aluminium wire. Consult Factory for Use of Conductors Rated Lower than 90°C.

\*\* Consult Factory

Notes:  
1 - Controller is phase sensitive. Incoming lines must be connected in ZS sequence.

Drawing for information only.  
Manufacturer reserves the right to modify this drawing without notice.  
Contact manufacturer for "As Built" drawing.



© Tornatech, Inc. Not for construction.  
Subject to change without notice.

BY		DD/MM/YY	
DRAWN BY	ZS	10/07/23	
FINAL APPROVAL	FC	10/07/23	

# ELECTRIC FIRE PUMP CONTROLLER

**MODEL: VPA / VPS**

BUILT TO THE LATEST EDITION OF THE NFPA20 & NFPA70



DRAWING NUMBER	VPX-TD801 / E
DWG REV. 0	
SHEET 1 OF 1	

## COPPER CONDUCTORS for Motor Connection (1M).

Field Wiring According to Bending Space (AWG or MCM). Terminals T1 - T2 - T3

HP Voltage	5	7.5	10	15	20	25	30	40	50	60	75	100
200	1x (10 to 2)	1x (8 to 2)	1x (8 to 2)	1x (6 to 2)	1x (4 to 2)	1x (3 to 2/0)	1x (2 to 2/0)	1x (1/0 to 3/0)	1x (3/0)	1x (4/0 to 300)	1x (300)	-----
208	1x (10 to 2)	1x (8 to 2)	1x (8 to 2)	1x (6 to 2)	1x (4 to 2)	1x (3 to 2/0)	1x (2 to 2/0)	1x (1/0 to 3/0)	1x (3/0)	1x (4/0 to 300)	1x (300)	2x (2/0 to 300)
220 to 240	1x (10 to 2)	1x (10 to 2)	1x (8 to 2)	1x (6 to 2)	1x (4 to 2)	1x (4 to 2/0)	1x (3 to 2/0)	1x (1/0 to 3/0)	1x (2/0 to 3/0)	1x (3/0)	1x (250 to 300)	2x (2/0 to 300)
380 to 416	1x (10 to 2)	1x (10 to 2)	1x (10 to 2)	1x (8 to 2)	1x (8 to 2)	1x (6 to 2)	1x (6 to 1/0)	1x (4 to 1/0)	1x (3 to 2/0)	1x (1 to 2/0)	1x (1/0 to 3/0)	1x (3/0)
440 to 480	1x (10 to 2)	1x (10 to 2)	1x (10 to 2)	1x (10 to 2)	1x (8 to 2)	1x (8 to 2)	1x (6 to 2)	1x (6 to 2)	1x (4 to 2/0)	1x (3 to 2/0)	1x (1 to 1/0)	1x (2/0 to 3/0)
600	1x (10 to 2)	1x (10 to 2)	1x (10 to 2)	1x (10 to 2)	1x (10 to 2)	1x (8 to 2)	1x (8 to 2)	1x (6 to 2)	1x (6 to 2)	1x (4 to 2/0)	1x (3 to 1/0)	1x (1 to 1/0)

HP Voltage	125	150	200	250	300	350	400	450
380 to 416	1x (250 to 300)	1x (300)	2x (3/0 to 300)	2x (4/0 to 300)	2x (300)	2x (400 to 500)	-----	-----
440 to 480	1x (3/0)	1x (4/0 to 300)	2x (1/0 to 300)	2x (3/0 to 300)	2x (4/0 to 300)	2x (300)	2x (350 to 500)	2x (400 to 600)

## Motor Terminals

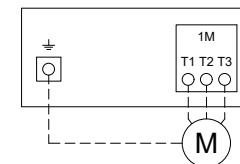

Models: VPA / VPS

## ALUMINIUM CONDUCTORS for Contactor (1M).

Field Wiring According to Bending Space (AWG or MCM). Terminals T1 - T2 - T3

HP Voltage	5	7.5	10	15	20	25	30	40	50	60	75	100
200	1x (10 to 2/0) **	1x (10 to 2/0) **	1x (6 to 2/0) **	1x (4 to 2/0) **	1x (2 to 2/0) **	1x (1 to 2/0) **	1x (1/0 to 2/0) **	1x (2/0) 90°C *	Consult Factory	1x (300)	1x (300) 90°C *	-----
208	1x (10 to 2/0) **	1x (10 to 2/0) **	1x (6 to 2/0) **	1x (4 to 2/0) **	1x (2 to 2/0) **	1x (1 to 2/0) **	1x (1/0 to 2/0) **	1x (2/0) 90°C *	Consult Factory	1x (300)	1x (300) 90°C *	2x (4/0 to 300)
220 to 240	1x (10 to 2/0) **	1x (10 to 2/0) **	1x (8 to 2/0) **	1x (4 to 2/0) **	1x (3 to 2/0) **	1x (2 to 2/0) **	1x (1 to 2/0) **	1x (2/0)	1x (3/0) 90°C *	Consult Factory	1x (300) 90°C *	2x (3/0 to 300)
380 to 416	1x (12 to 2/0) **	1x (12 to 2/0) **	1x (10 to 2/0) **	1x (8 to 2/0) **	1x (6 to 2/0) **	1x (6 to 2/0) **	1x (4 to 2/0) **	1x (2 to 2/0) **	1x (1 to 1/0)	1x (1/0)	1x (3/0)	Consult Factory
440 to 480	1x (12 to 2/0) **	1x (12 to 2/0) **	1x (10 to 2/0) **	1x (10 to 2/0) **	1x (8 to 2/0) **	1x (6 to 2/0) **	1x (6 to 2/0) **	1x (4 to 2/0) **	1x (2 to 1/0)	1x (1 to 1/0)	1x (1/0)	1x (3/0)
600	1x (12 to 2/0) **	1x (12 to 2/0) **	1x (12 to 2/0) **	1x (10 to 2/0) **	1x (10 to 2/0) **	1x (8 to 2/0) **	1x (8 to 2/0) **	1x (4 to 2/0) **	1x (4 to 2/0) **	1x (2 to 1/0)	1x (1 to 1/0)	Consult Factory

HP Voltage	125	150	200	250	300	350	400	450
380 to 416	1x (300) 90°C *	Consult Factory	2x (4/0 to 300)	2x (300)	Consult Factory	2x (600)	-----	-----
440 to 480	Consult Factory	1x (300)	2x (3/0 to 300)	2x (250 to 300)	2x (300)	2x (300) 90°C *	2x (500)	2x (600)

\*For standard enclosure, use 90°C aluminium wire. Consult Factory for Use of Conductors Rated Lower than 90°C.

\*\* Option V659 required.

### Notes:

- 1 - For proper wire sizing, refer to NFPA70 and NEC (USA) or CEC (Canada) or local code.
- 2 - Controller suitable for service entrance in USA.
- 3 - For more accurate motor connections refer to motor manufacturer or motor nameplate.
- 4 - Controller is phase sensitive. Incoming lines must be connected in ZS sequence.

Drawing for information only.  
Manufacturer reserves the right to modify this drawing without notice.  
Contact manufacturer for "As Built" drawing.



BY DD/MM/YY

DRAWN BY ZS 10/07/23

FINAL APPROVAL FC 10/07/23

© Tornatech, Inc. Not for construction. Subject to change without notice.

# ELECTRIC FIRE PUMP CONTROLLER

## MODEL: VPS

BUILT TO THE LATEST EDITION OF THE NFPA20 & NFPA70



DRAWING NUMBER  
VPS-TD800 /E  
DWG REV. 0  
SHEET 1 OF 1

### Field Connections

Terminals Wire Size:  
24 - 12 AWG  
0.5 Nm

- Remote Manual
- Lockout
- Remote Auto
- Deluge Valve
- Low Water Level

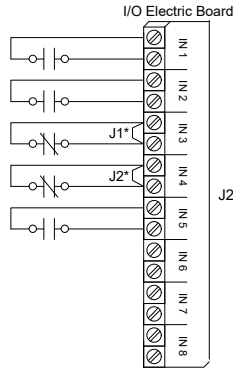

### Network Connections

Terminals Wire Size:  
Shielded Female Connector RJ45

Modbus TCP/IP RJ45

Located on Main Board



### Alarm Contacts

Terminals Wire Size:  
24 - 12 AWG  
0.5 Nm

24 - 12 AWG  
0.5 Nm

Controller Terminal Strip

Motor Run

Power Available

Normal Power Phase Reversal

Pump Room Alarm

Motor Trouble

I/O Electric Board

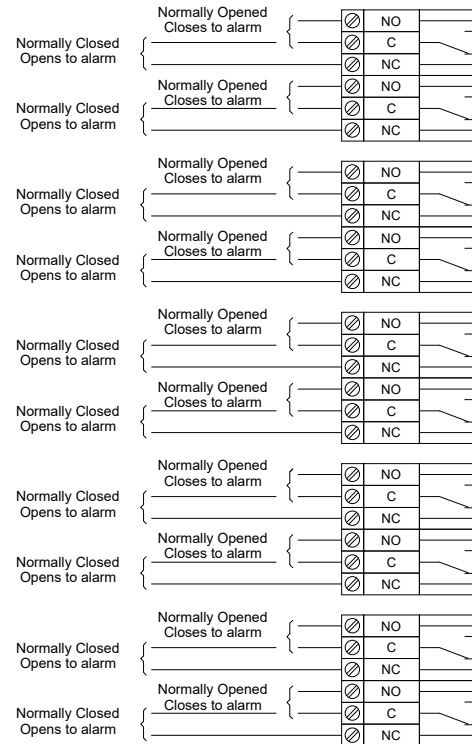

Bypass Mode

VFD Failure

Overpressure

Expansion Board 2

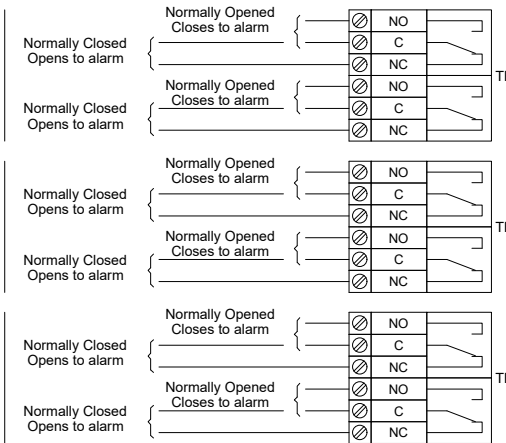

\* Remove jumper to use this feature



© Tornatech, Inc. Not for construction.  
Subject to change without notice.

	BY	DD/MM/YY
DRAWN BY	ZS	21/07/23
FINAL APPROVAL	FC	21/07/23

# AUTOMATIC TRANSFER SWITCH FOR ELECTRIC FIRE PUMP CONTROLLER

## MODEL: VPU

BUILT TO THE LATEST EDITION OF THE NFPA20 & NFPA70



DRAWING NUMBER	VPU-TD801/E
DWG REV.	0
SHEET	1 OF 1

### Remote Alarm Terminals (TSB1)

Terminals Wire Size:  
24 - 12 AWG  
0.5 Nm

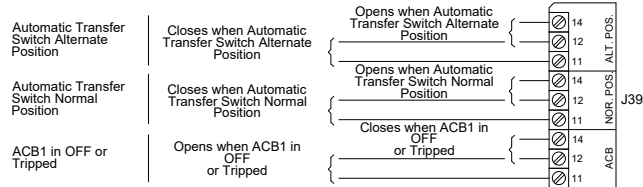

### Control Terminals (TSB1)

Terminals Wire Size:  
24 - 12 AWG  
0.5 Nm

